



Decide with Confidence  
DUNS NO. : 86-917-7745



# **DS-LOK**

INSTRUMENTATION VALVES AND FITTINGS



## **TUBE FITTINGS**

- Sizes: 1/2" to 3"
- Pressure Ratings: 150# To 2500#
- Carbon steel LF2, F51, Duplex, Super Duplex, Monel 400, Hastelloy C276, Inconel 625 Titanium, Incolloy 825,



## Company Profile

DS-LOK Engineers is a professional undertaking established in 1996 to manufacture and export fluid process components namely Tube Fittings, Pipeline Fittings, Tubes, Valves (Needle, Ball, Check, Gate, Globe) Manifolds Valves, Gauge Cock, Gouge Saver, Pulsation Dampners, Syphons, Thermowells, Quick Release Coupling, Condensate Pots, Sampling Cylinder, Orifice Plate Assembly, Flanges, Studs, Nuts, Air Headers, and other accessories pertaining to process instrumentation. The products are manufactured from Bar Stock and Shaped Forged in SS-316, Carbon Steel, Brass, Monel, Incoloy, Hastelloy, SS-316L.

### Corporate Mission

DS-LOK Engineers work towards well-defined objectives, conforming to the highest manufacturing and procedural guidelines aimed to present to the local and global market quality products that must compare with the best internationally.

- Petrochemical
- Boiler Plant Assembly
- Fertilizer
- Cement
- Oil and Natural Gas

The Company is thoroughly equipped to cater to the most stringent and exacting demands. Located at GIDC the most celebrated industrial enclave in Anandabad, the well-known industrial city in India, DS-LOK's operations are carried out in a plant having modern state-of-the-art equipment, including a sophisticated testing and inspection lab.

DS-LOK Engineers processes its premium components further in the following departments.

### Quality Control & Management

Quality is the main priority determining product integrity at DS-LOK Engineers. To maintain standards the Company maintains a state-of-the-art R & D and inspection Department where every product is subjected to quality tests from the raw material stage to the finished products. These exercises and procedures are an unalienable aspect of QC and are monitored by thorough documentation as a follow-up on the stage manufacturing of the product.

### Towards excellence

The Company's aim is not just the well-known word "quality" but all those little details that accomplish quality, especially those characteristics that make up attitude to work, percolating to become an inborn corporate creed. So, in reaping performance, appreciation, and inquiries, DS-LOK Engineers is not complacent about its input but strives to equal and even excel previous performance.

### Design Features

DS-LOK tube fitting are designed of four precision engineered components (as shown in following fig.) all fittings have been designed to meet the most stringent demands of quality tube line fabrication.

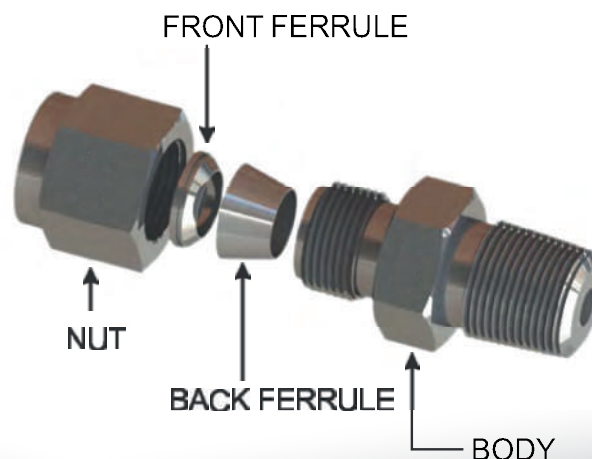

## FEATURES

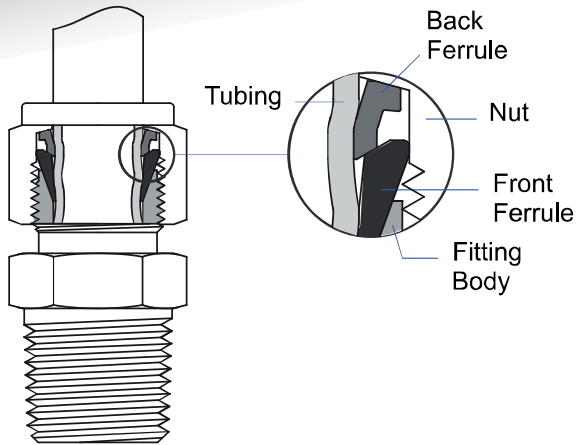

When the nut is tightened, the back ferrule is driven against the tapered rear of the front ferrule. The front ferrule is driven by force into the tapered mouth of the fitting body and creates a primary tubing seal. The back ferrule consistently grips the tubes to hold the fitting and tubing firmly in place while the front ferrule forms a full-faces seal on the tapered surface of the body. In the twin-ferrule tube fitting design, the back and front ferrules move axially instead of a rotary motion. No torque is transferred to the tubing during installation.

### Two ferrules are optimized to provide sealing and tube gripping function.

The front ferrule creates a seal:

- Against the fitting body.
- On the tubing outside diameter.

### As the nut is tightened, the back ferrule:

- Axially advances the front ferrule.
- Radially provides an effective tube grip.

Although the fittings consist of four components: Nut, back ferrule, front ferrule and the body, it becomes a four piece connection when affixed to tubing. The two ferrule design and sequential action of the fittings overcome in-variation of tube wall thickness and hardness to assure safe, reliable, leak-free connections. **DS-LOK** tube fittings are easily installed without any special tools. The front ferrule swages into the tube as it moves down the cone of the body creating a pressure/vacuum tight seal on both tube and body by interface pressure and surface finish of marching components. The back ferrule, deforms into the tube creating a strong mechanical and anti.vibration hold on the tube. The internal diameter of body and nut are closely controlled which constrain the tube within a close tolerance of its axis ensuring accurate alignment within the assembled fitting. In case of S.S. tube fitting high hardness of ferrules is assured/maintained (more than Rb 90) For reliable joints the positive tolerance on inside diameter of ferrules and body is kept to minimum. The nut threads are **silver coated to ensure no galling**.

Thus the design features on the tube end side can be summarised as below.

1. The back ferrule dampens the tube circuit vibration through a spring like action. Further more, it prevents a carry over of tightening torque from the fitting nut to front ferrule.
2. The front ferrule circumferentially seals the surface between the tube and fitting. The inner taper of front ferrule is pressed on the tube so that a pressure tight impression is formed.
3. Silvering of nut threads prevents seizing/galling. This allows repeated use of fittings.
4. A deep body bore on tube side and taper, guarantees accurate positioning and centering of tube.

The DS-LOK twin ferrule connection does not in any way reduce the strength of the tube and therefore tube having thin wall can be used without affecting the safety of installation.

**When the assembly is fully tightened, Sealing action of DS-LOK Tube Fittings takes place as well as below illustrated figure.**

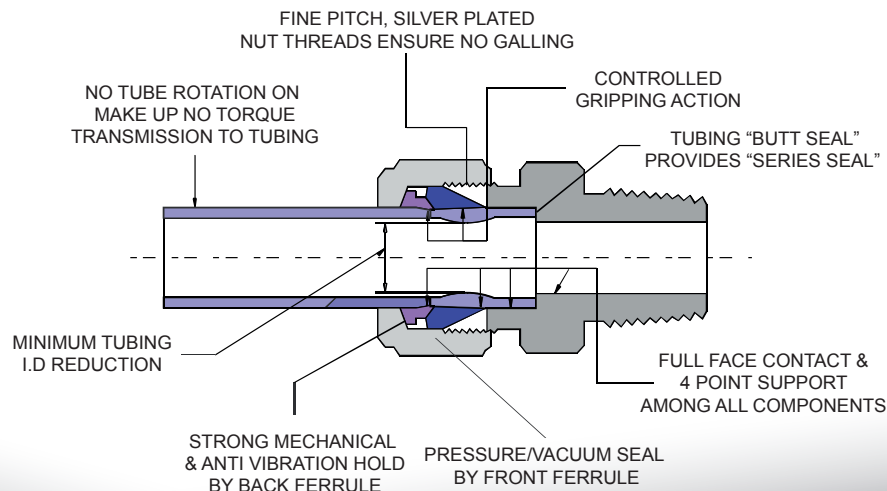

On the pipe end connection side of fittings, most widely used “NPT” threads are machined and rolled as per ANSI B2. 1/ANSI B1.20.1 For leak proof connection suitable sealing material (Teflon tape/paste) should be used. The straight threads are fine threads machined as per ANSI B1.1 or equivalent standards. Some of the important features/characteristics of DS-LOK Twin ferrule tube fittings are:

- Withstands high pressure and vacuum
- Leak tight assembly from vacuum to high pressure is assured
- Excellent make and re-make life
- No Twisting of tubes while assembly
- Assembling with self aligning front and back ferrule
- No transmission of torque on tubing while assembly
- Controlled tightening, no distortion of tube, no rupture of tube fibres and minimum reduction of tube bore size.
- Low tightening torque (the nut being of non binding design)
- Fittings can be used with thin and thick walled tubing. (As per guidelines of Table 1,2 & 3)
- Silver plated nut to avoid galling and give low assembly torque. No pre-lubrication needed.
- Fittings can be used (ensuring leak tightness) in low to high temperature range.
- Anti-vibration hold on the tube (Vibration resistant)

#### IDENTIFICATION OF METRIC TUBE FITTINGS

Metric tube fittings are identified by a stepped shoulder on both the body and the threaded end of the nut as illustrated in the following fig.

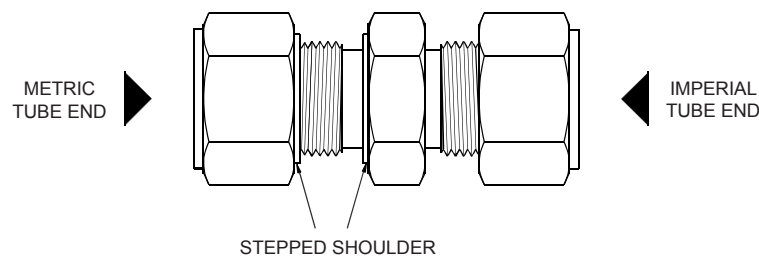

#### INSTALLATION INSTRUCTIONS OF DS-LOK TUBE FITTINGS

Ensure that the end of the tube is cutsquare and deburred.

- 1) Simply insert the tubing into DS-LOK tube fittings. Make sure that the tube is firmly rest on the shoulder of the fitting and that nut is finger tight.



- 2) Before tightening the DS-LOK nut, scribe the nut at the 6.00 'o' clock position as illustrated in the below figure

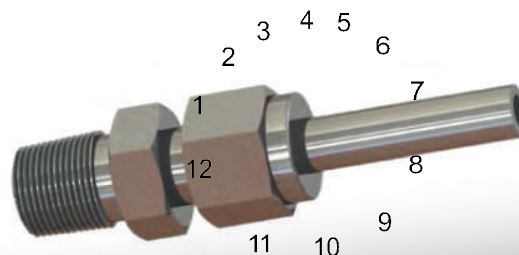

3) Now while holding the fitting body firmly with a backup wrench, tighten the nut one and one quarter Turns, watch the scribe mark make one complete revolution and continue to 9 o'clock position.

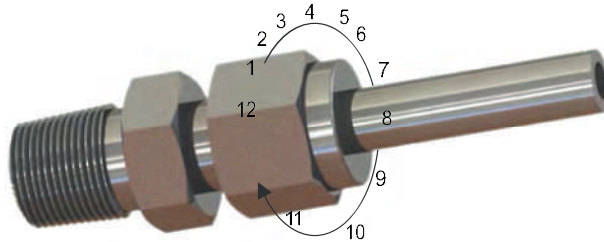

Note:

Due to variation in tube diameters for high pressure and safety systems, a common starting point is desirable. To achieve this (a wrench snug up the nut until the tube cannot be rotated by hand. From this point the nut should be rotated one and a quarter turns.)  
For sizes upto 1/8" in imperial tube fittings and 4 mm in metric tube fittings only 3/4 tum from finger tight position is necessary.

#### RE-ASSEMBLY INSTRUCTIONS OF DS-LOK TUBE FITTINGS

With DS-LOK tube fittings the connection can be disconnected and retightened many times and the same reliable, safe and leak proof connection can be obtained. For re-assembly the following steps should be followed.

1) Insert tube with ferrules into the tube fitting until front ferrule seats in fittings.



2) Holding the body with spanner, the nut is tightened to the original position and the given a slight extra effort to retain positive sealing.

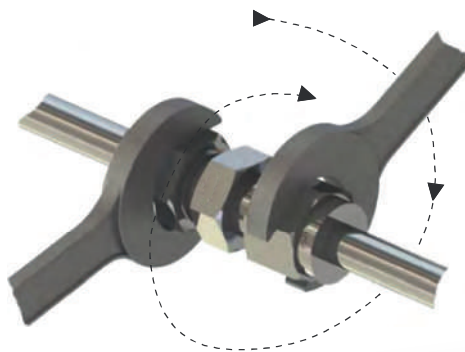

## **PIPE THREAD CONNECTION**

Most widely used NPT threads have been machined for connecting the thread fittings. Leak tightness is not achieved by the thread alone without sealant. Commercially available Teflon tape/paste is to be used to provide sealing and lubricating agent. Wrap the tape 4 to 5 layers around the male threads in a clockwise direction. Ensure that the tape/paste does not over hang the first thread.

## **SELECTION OF TUBING**

The DS-LOK twin ferrule tube fitting is precision engineered to exacting standards. Careful selection of high quality tubing together with appropriate DS-LOK fitting will ensure the installation of safe, leak free systems.

DS-LOK tube fittings are designed to work on line material. Stainless steel fittings should be used with S.S. tubing. The practice of mixing material is strongly discouraged. The only exception is brass fittings with copper tubing.

Disimilar materials in contact maybe be susceptible to galvanic corrosion. Further different materials have a diferent levels of hardness, and can be adversely affect the fittings ability to seal on the tubing.

The tubing wall thickness is decided based on maxium pressure rating. Thick wailed tubing helps to provide resistance. Very low wall thickness of tubing may result in unrealible joints. For DS-LOK S.S. tube fittings seamless S.S. 316/316L/ASTM-A-213 NACE MR 0175 is recommended.

DS-LOK tube fittings are normally not recommended for tube wall thickness outside the ranges show in Table I, II & III.

The key to proper tube hardness for use with DS-LOK tube fittings is that the tubing should be softer than the fitting material. Based on this, preferred hardness of tubing is Rb 80 or less. If harder tube is used the maximum hardness should noy exceed Rb90.

## **TUBING FOR GAS SERVICE**

Special care may be taken while selecting tubing for gas service. In gasses even a small surface defect may provide a leak path. In order to achieve a das tigth seal, ferrules in instrument fittings must seal any surface imperfections. This is accomplished by the ferrules penetrating the surface of the tubing.

Penetration can only be achieved if the tubing provides radial resistance an if the tubing material is softer than th ferrules. Though maximum allowable hardness of S.S. tubing as per ASTM 269/213 is Rb 90, preferred hardness of tubing should be Rb or less for reliable and leak proof joints mainly in gas application.

The suggested minimum wall thickness of S.S. tubing for gas service for different sizes of tubing is given in following table.

## **SUGGESTED MINIMUM WALL THINCKNESS OF S.S. TUBING GAS SERVICE**



TUBE O.D. (Inch)	SUGGESTED MINIMUM WALL THICKNESS (Inch)
1/8	0.028
3/16	0.028
1/4	0.028
5/6	0.035
3/8	0.035
1/2	0.041
5/8	0.052
3/4	0.062
7/8	0.073
1	0.083

#### RECOMMENDED MAXIMUM WORKING PRESSURE FOR DIFFERENT TUBING

The maximum allowable working pressure for different tubings (as given in following tables) have been calculated using the maximum allowable stress levels in accordance with ANSI B 31.3. The calculations are based on nominal wall thickness and at ambient temp. At higher temperature the maximum working pressure will be less as the allowable stress will be reduced. The maximum working pressure in the following tables have been given only for recommended minimum to maximum wall thickness for different sizes of tubing.

TABLE 2.  
RECOMMENDED MAXIMUM WORKING PRESSURE FOR STEEL (SEAMLESS) IN POUNDS PER SQUARE INCH.

TUBE O.D. (Inch)	TUBE WALL THICKNESS (inch)							
	0.028	0.035	0.049	0.065	0.083	0.095	0.109	0.120
1/8	8600	11200	-	-	-	-	-	-
3/16	5500	7000	10400	-	-	-	-	-
1/4	4000	5100	7500	10500	-	-	-	-
5/6	-	4100	5900	8100	-	-	-	-
3/8	-	3300	4800	6600	-	-	-	-
1/2	-	2500	3500	4800	6300	-	-	-
5/8	-	-	3000	4000	5200	6100	-	-
3/4	-	-	2400	3300	4300	5000	5800	-
7/8	-	-	2100	2800	3600	4200	4900	-
1	-	-	-	2400	3200	3700	4200	4700

TABLE 2.  
RECOMMENDED MAXIMUM WORKING PRESSURE FOR STEEL (SEAMLESS) IN POUNDS PER SQUARE INCH.

TUBE O.D. (Inch)	TUBE WALL THICKNESS (inch)							
	0.028	0.035	0.049	0.065	0.083	0.095	0.109	0.120
1/8	8200	10900	-	-	-	-	-	-
3/16	5200	6700	10100	-	-	-	-	-
1/4	3800	4900	7200	10100	-	-	-	-
5/6	-	3800	5500	7700	-	-	-	-
3/8	-	3100	4500	6200	-	-	-	-
1/2	-	2300	3300	4500	6000	-	-	-
5/8	-	1800	2600	3500	4600	5400	-	-
3/4	-	-	2200	2900	3800	4400	5100	-
7/8	-	-	1800	2500	3200	3700	4300	-
1	-	-	1600	2100	2800	3200	3700	4100

TABLE 3.  
RECOMMENDEN MAXIUM WORKING PRESSURE FOR COPPER (SEAMLESS) TUBING POUNDS PER SQUARE INCH.

TUBE O.D. (Inch)	TUBE WALL THICKNESS (inch)							
	0.028	0.035	0.049	0.065	0.083	0.095	0.109	0.120
1/8	2800	3800	-	-	-	-	-	-
3/16	1600	2300	3600	-	-	-	-	-
1/4	-	1700	2600	3600	-	-	-	-
5/6	-	1700	2000	2800	-	-	-	-
3/8	-	1100	1600	2300	-	-	-	-
1/2	-	800	1200	1600	2100	-	-	-
5/8	-	-	900	1300	1700	2000	-	-
3/4	-	-	800	1000	1400	1600	1900	-
7/8	-	-	600	900	1100	1300	1600	-
1	-	-	550	800	1000	1200	1400	-

#### QUALITY ASSURANCE PLAN

DS-LOK Twin ferrule tube fittings are manufactured to conform with the applicable sections of the American standard code for pressure piping (ASME codes). Manufacturing process is precisely controlled by a well established and approved quality assurance programme.

Manufacturing is started onlyb after verifying the chemical composition and hardness of raw material. Unless otherwise asked for special material, DS-LOK twin ferrule tube fittings are manufactured from S.S. 316L material. All bar stock items, i.e. nut ferrules and straight connectors, unions, etc. are manufactured from S.S. 316L meeting ASTM-A-479/276 NACE MR0175 requirements. All shaped fittings i.e. tees, elbows, etc. are manufactured from forgings meeting requirements of ASTM-A-182...

Batch production of fittings is allowed only after qualitification of sample fittig parts. Internal bores, seat angle, tube bore depth, ferrule and body inner dimensions and pipe threads are checked on 100% basis.



To check the mechanical conformance on the fittings/parts the following test are performed:

- A) Material Test
- B) Hydro Test
- C) Vibration Test
- D) Leak Test
- E) Dimensional Conformance Test
- F) Hardness Test

Hardness test on ferrules, pressure test, make remake test, pull out test, pressure & temp cycling tests are done on limited samples selected randomly from the lot and in case of any failure, full lot is tested for above tests.

In house Extensive test facility in being developed for performing different test on tube fittings.

#### **SAFETY AND PRECAUTION UN USING DS-LOK TUBE FITTINGS**

- 1) Select proper tubing with DS-LOK tube fittings. Seamless tubing is recommended.
- 2) Avoid combining or mixing materials of fittings when system is pressurised.
- 3) Do not make up or tighten fittings when system in pressurised.
- 4) Never turn fitting body. Hold body and turn nut.
- 5) Do not bleed down system by loosening fittings nut or plug.
- 6) Always use proper thread sealant and lubricants on tapered pipe threads.
- 7) Total system design must be considered to assure safe & trouble free performance. Material compatibility, adequate rating, proper installation operation and maintenance are the responsibility of the system engineer and user.
- 8) Tubing materials should always be softer than the fitting material S.S. tubing should not be used with Brass fittings.
- 9) Tubing should be fully annealed if tubing and fitting material is same.
- 10) Extremes (Minimum and maximum) of wall thickness should always be checked as per guidelines of Table 1, 2 & 3.
- 11) Surface finish is very important for proper sealing. Tubing with any kind of depression, scratch, raised portion or other surface defect will be difficult to seal particularly on gas service.
- 12) Tubing which has oval end does not easily fit through fitting nut, ferrule and body should never be forced into the fitting.

#### **Warning**

Failure, improper selection or improper use of the products and/or system described herein or related items can cause death, personal injury and property damage.

## MATERIALS

DS-LOK twin ferrule tube fittings shown in this catalogue are mainly manufactured from stainless steel - 316 material conforming to chemical requirements of standards as given in the following table. On request the DS-LOK tube fittings can be supplied in S.S. 304, brass, steel and monel materials conforming to the specifications listed below.

Material	Brastock	Brastock
Stainless Steel (316 & 304)	ASTM-A-276 NACE MR 0175 ASTM-A-479 BS-970 DIN-4401	ASTM-A-182, BS-970 DIN-4401
Brass	ASTM-B-16 ASTM-B453 BS-2874	ASTM-B-124 BS-2872
Steel	ASTM-A-108	ASTM-A576
Monel	ASTM-B-164 BS-3076	ASTM-B-164 BS-3076

Material availability in fittings on request

Titanium, Hastelloy C, duplex material and other exotic Material on request.

### MATERIAL CODE:

The following symbols are used to indicate different types of material.

316= Stainless steel - 316	316L= Stainless steel
304= Stainless steel - 304	304L= Stainless steel
S= Steel/Carbon steel	B= Brass
M= Monel	

### Notes:

This catalogue mainly covers twin type S.S. 316/304 tube fitting for imperial as well as metric tubing with NPT threads as per ANSI B1.20.1 (wherever applicable). Based on requirement, fittings in other material like carbon steel, brass or monel and with BSPT/BSPP thread can also be supplied.

Most widely used sizes of tube fittings have been covered in this catalogue but other sizes can also be supplied on demand. The dimensions given in this catalogue are nominal dimensions of fittings in hand tight position.

DS-LOK tube fittings are manufactured to close tolerance and controlled quality. Manufacturing process is precisely controlled by well established/approved quality assurance programme. Controlled tolerance and surface finish guarantee leak proof tubing connections in high pressure and vacuum applications.

## HOW TO ORDER

DS-LOK tube fittings are ordered by part numbers as listed in this catalogue.

This may be noted that the part number mentioned in this catalogue does not indicate the material of fittings which should be indicated while ordering the fittings. Fittings being supplied based on part number includes body of fitting, back ferrule and front ferrule.

Size: Imperial tube and pipe thread sizes are designated by the number of sixteenth of an inch.

e.g. 1/2" Tube = 8/16+8, 3/8"NPT=6/16=6

Metric tube is designated in millimeters and prefixed "M"

e.g. 12mm tube=M12. The thread size is written in the way as in case of imperial tubing.

## FITTING TYPE

A letter or combination of letters are used to designate the type of fittings.

e.g. DMC: Male Connector

## CODES FOR THREAD TYPE

N= NPT as per ANSI B.120.1

K= BSPT

R= BSPP

## PART NUMBER

DS-LOK tube fitting part numbers are constructed from symbols that identify the size, type of fitting and material used.

Example:

a) 3/8" OD x 1/2 NPT SS316 Male Connector

6	MC	8	N	316
TUBE O. D.	TYPE	THREAD	THREAD TYPE	S. S. 316
3/8"	MALE CONNECTOR	SIZE 1/2"	NPT	

PART NUMBER - DMC8N-316

b) 10 m.m. O.D. x 3/8" NPT, S.S. 316- Female Connector

DM10	FC	3/8"	N	316
TUBE O. D.	TYPE	THREAD	THREAD TYPE	MATERIAL
10mm	FEMALE CONNECTOR	SIZE 3/8"	NPT	S. S. 316

PART NUMBER - DM10 FC 6N 316

## MALE CONNECTOR

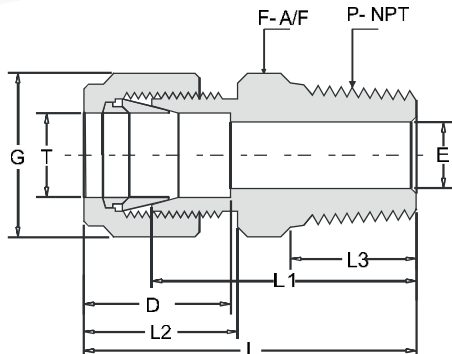

T TUBE OD O.D.	P-NPT MALE THREAD	PART NO.	L	L1	L2	L3	D	E	F HAX FLAT	G HEX FLAT
----------------------	-------------------------	----------	---	----	----	----	---	---	------------------	------------------

### DIMENSION IN INCHES

1/8	1/8	D-IMC2-2	1.20	0.94	0.60	0.38	0.50	0.09	7/16	7/16
1/8	1/4	D-IMC2-4	1.40	1.14	0.60	0.56	0.50	0.09	9/16	7/16
1/8	3/8	D-IMC2-6	1.42	1.15	0.60	0.56	0.50	0.09	11/16	7/16
1/8	1/2	D-IMC2-8	1.67	1.40	0.60	0.75	0.50	0.09	7/8	7/16
1/4	1/8	D-IMC4-2	1.29	1.00	0.70	0.38	0.60	0.19	1/2	9/16
1/4	1/4	D-IMC4-4	1.49	1.20	0.70	0.56	0.60	0.19	9/16	9/16
1/4	3/8	D-IMC4-6	1.51	1.22	0.70	0.56	0.60	0.19	11/16	9/16
1/4	1/2	D-IMC4-8	1.76	1.47	0.70	0.75	0.60	0.19	7/8	9/16
1/4	3/4	D-IMC4-12	1.82	1.53	0.70	0.75	0.60	0.19	1-1/16	9/16
5/16	1/8	D-IMC5-2	1.34	1.05	0.73	0.38	0.64	0.19	9/16	5/8
5/16	1/4	D-IMC5-4	1.52	1.23	0.73	0.56	0.64	0.25	9/16	5/8
5/16	3/8	D-IMC5-6	1.55	1.25	0.73	0.56	0.64	0.25	11/16	5/8
3/8	1/8	D-IMC6-2	1.38	1.10	0.76	0.38	0.66	0.19	5/8	11/16
3/8	1/4	D-IMC6-4	1.57	1.28	0.76	0.56	0.66	0.28	5/8	11/16
3/8	3/8	D-IMC6-6	1.57	1.28	0.76	0.56	0.66	0.28	11/16	11/16
3/8	1/2	D-IMC6-8	1.82	1.53	0.76	0.75	0.66	0.28	7/8	11/16
3/8	3/4	D-IMC6-12	1.88	1.59	0.76	0.75	0.90	0.28	1-1/16	11/16
1/2	1/8	D-IMC8-2	1.53	1.13	0.86	0.38	0.90	0.19	13/16	7/8
1/2	1/4	D-IMC8-4	1.71	1.31	0.86	0.56	0.90	0.28	13/16	7/8
1/2	3/8	D-IMC8-6	1.71	1.31	0.86	0.56	0.90	0.38	13/16	7/8
1/2	1/2	D-IMC8-8	1.93	1.53	0.86	0.75	0.90	0.41	7/8	7/8
1/2	3/4	D-IMC8-12	1.99	1.59	0.86	0.75	0.90	0.41	1-1/16	7/8
1/2	1	D-IMC8-16	2.25	1.85	0.86	0.94	0.90	0.41	1-3/8	7/8
5/8	3/8	D-IMC10-6	1.74	1.34	0.86	0.56	0.96	0.38	15/16	1
5/8	1/2	D-IMC10-8	1.93	1.53	0.86	0.75	0.96	0.47	15/16	1
5/8	3/4	D-IMC10-12	1.99	1.59	0.86	0.75	0.96	0.50	1-1/16	1
3/4	1/2	D-IMC12-8	1.99	1.59	0.86	0.75	0.96	0.47	1-1/16	1-1/8
3/4	3/4	D-IMC12-12	1.99	1.59	0.86	0.75	0.96	0.62	1-1/16	1-1/8
3/4	1	D-IMC12-16	2.28	1.85	0.86	0.94	0.96	0.62	1-3/8	1-1/8
1	1/2	D-IMC16-8	2.27	1.78	1.05	0.75	1.23	0.47	1-3/8	1-1/2
1	3/4	D-IMC16-12	2.27	1.78	1.05	0.75	1.23	0.62	1-3/8	1-1/2
1	1	D-IMC16-16	2.46	1.97	1.05	0.94	1.23	0.88	1-3/8	1-1/2

## MALE CONNECTOR

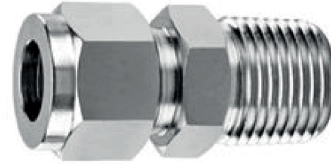
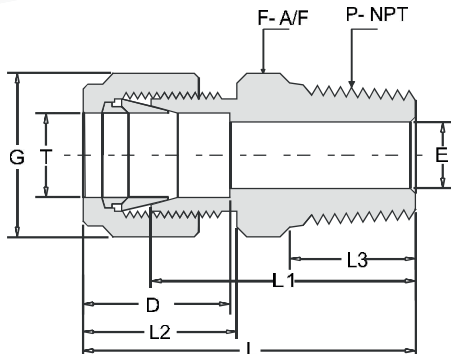

T TUBE OD O.D.	P-NPT MALE THREAD	PART NO.	L	L1	L2	L3	D	E	F HAX FLAT	G HEX FLAT
----------------------	-------------------------	----------	---	----	----	----	---	---	------------------	------------------

### DIMENSION IN MILLIMETERS

6	1/8	D-MMC6-2	32.8	25.4	17.7	9.7	15.3	4.8	14	14
6	1/4	D-MMC6-4	37.9	30.5	17.7	14.2	15.3	4.8	14	14
6	3/8	D-MMC6-6	38.4	31.0	17.7	14.2	15.3	4.8	18	14
6	1/2	D-MMC6-8	44.7	37.3	17.7	19.0	16.2	4.8	22	14
8	1/8	D-MMC8-2	34.2	26.7	18.6	9.7	16.2	4.8	15	16
8	1/4	D-MMC8-4	38.7	31.2	18.6	14.2	16.2	6.4	15	16
8	3/8	D-MMC8-6	39.3	31.8	18.6	14.2	16.2	6.4	18	16
8	1/2	D-MMC8-8	45.6	38.1	18.6	19.0	16.2	6.4	22	16
10	1/8	D-MMC10-2	36.3	28.7	19.5	9.5	17.2	4.8	18	19
10	1/4	D-MMC10-4	40.9	33.3	19.5	14.2	17.2	7.9	18	19
10	3/8	D-MMC10-6	40.9	33.3	19.5	14.2	17.2	7.9	18	19
10	1/2	D-MMC10-8	46.5	38.9	19.5	19.0	17.2	7.9	22	19
10	3/4	D-MMC10-12	48.0	40.4	19.5	19.0	17.2	7.9	27	19
12	1/4	D-MMC12-4	43.4	33.3	22.0	14.2	22.8	7.1	22	22
12	3/8	D-MMC12-6	43.4	33.3	22.0	14.2	22.8	9.5	22	22
12	1/2	D-MMC12-8	49.0	38.9	22.0	19.0	22.8	9.5	22	22
12	3/4	D-MMC12-12	50.5	40.4	22.0	19.0	22.8	9.5	27	22
14	1/4	D-MMC14-4	44.1	34.0	22.0	14.2	24.4	7.1	24	25
14	3/8	D-MMC14-6	44.1	34.0	22.0	14.2	24.4	9.5	24	25
14	1/2	D-MMC14-8	49.0	38.9	22.0	19.0	24.4	11.1	24	25
15	1/2	D-MMC15-8	49.0	38.9	22.0	19.0	24.4	11.9	24	25
16	3/8	D-MMC16-6	44.1	34.0	22.0	14.2	24.4	9.5	24	25
16	1/2	D-MMC16-8	49.0	38.9	22.0	19.0	24.4	11.9	24	25
16	3/4	D-MMC16-12	50.5	40.4	22.0	19.0	24.4	12.7	27	30
18	1/2	D-MMC18-8	50.5	40.4	22.0	19.0	24.4	11.9	27	30
18	3/4	D-MMC18-12	50.5	40.4	22.0	19.0	24.4	15.1	27	30
20	1/2	D-MMC20-8	50.5	42.2	22.0	19.0	26.0	11.9	30	32
20	3/4	D-MMC20-12	52.3	42.2	22.0	19.0	26.0	15.9	30	32
22	3/4	D-MMC22-12	52.3	42.2	22.0	19.0	26.0	15.9	30	32
25	1/2	D-MMC25-8	57.5	45.2	26.5	19.0	31.3	11.1	35	38
25	3/4	D-MMC25-12	57.5	45.2	26.5	19.0	31.3	15.9	35	38
25	1	D-MMC25-16	62.3	50.0	26.5	23.9	31.3	21.8	35	38

## BULK HEAD MALE CONNECT

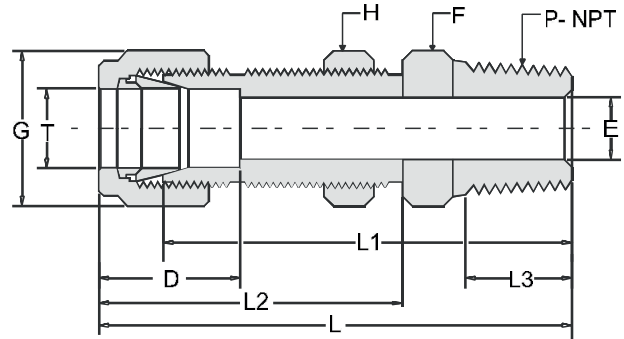
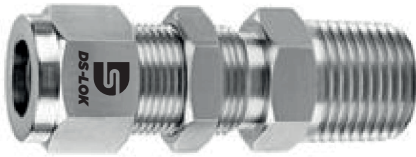

T TUBE O.D.	P-NPT MALE THREAD	PART NO.	L	L1	L2	L3	D	E	F HEX FLAT	G HEX FLAT	H HEX FLAT	PANEL HOLE SIZE	MAX. PANEL THICK
-------------------	-------------------------	----------	---	----	----	----	---	---	------------------	------------------	------------------	-----------------------	------------------------

DIMENSION IN INCHES

1/8	1/8	D-BIMC2-2	1.83	1.57	1.23	0.38	0.50	0.09	1/2	7/16	1/2	21/64	0.50
1/4	1/8	D-BIMC4-2	1.95	1.66	1.32	0.38	0.60	0.19	5/8	9/16	5/8	29/64	0.40
1/4	1/4	D-BIMC4-4	2.13	1.81	1.32	0.56	0.60	0.49	5/8	9/16	5/8	29/64	0.40
3/8	1/4	D-BIMC6-4	2.26	1.97	1.45	0.56	0.66	0.28	3/4	11/16	3/4	37/64	0.44
1/2	3/8	D-BIMC8-6	2.49	2.09	1.65	0.56	0.90	0.37	15/16	7/8	15/16	49/64	0.50
1/2	1/2	D-BIMC8-8	2.71	2.31	1.65	0.75	0.90	0.41	15/16	7/8	15/16	49/64	0.50
3/4	3/4	D-BIMC12-12	3.00	2.60	1.87	0.75	0.96	0.62	1-3/16	1-1/8	13/16	1-1/64	0.66
1	1	D-BIMC12-12	3.72	3.19	2.27	0.94	1.23	0.88	1-5/8	1-1/2	1-5/8	1-21/64	0.75

T TUBE O.D.	P-NPT MALE THREAD	PART NO.	L	L1	L2	L3	D	E	F HEX FLAT	G HEX FLAT	H HEX FLAT	PANEL HOLE SIZE	MAX. PANEL THICK
-------------------	-------------------------	----------	---	----	----	----	---	---	------------------	------------------	------------------	-----------------------	------------------------

DIMENSION IN MILLIMETERS

6	1/4	D-BIMC6-4	53.6	46.2	33.6	14.2	15.3	4.8	16	14	16	11.5	10.2
12	1/2	D-BIMC12-8	68.0	57.9	41.8	19.0	22.8	9.5	24	22	24	19.5	12.8



## MALE ELBOW

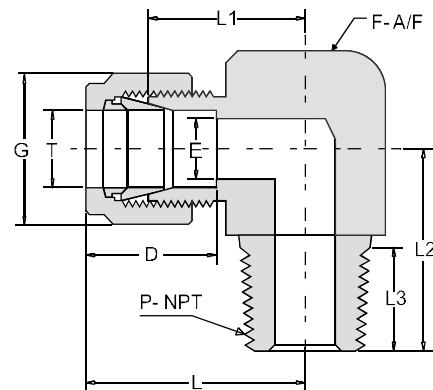

T TUBE O.D.	P-NPT MALE THREAD	PART NO.	L	L1	L2	L3	D	E	F Wrench Pad	G Hex Flat
-------------------	-------------------------	----------	---	----	----	----	---	---	--------------------	------------------

### DIMENSION IN INCHES

1/8	1/8	D-IME2-2	0.93	0.67	0.70	0.38	0.50	0.09	7/16	7/16
1/8	1/4	D-IME2-4	0.98	0.71	1.00	0.56	0.50	0.09	1/2	1/2
1/4	1/8	D-IME4-2	1.08	0.77	0.76	0.38	0.60	0.19	1/2	1/2
1/4	1/4	D-IME4-4	1.07	0.77	1.00	0.56	0.60	0.19	1/2	1/2
1/4	3/8	D-IME4-6	1.17	0.88	1.13	0.56	0.60	0.19	11/16	11/16
1/4	1/2	D-IME4-8	1.26	0.96	1.31	0.75	0.60	0.19	13/16	13/16
5/16	1/8	D-IME5-2	1.17	0.84	0.82	0.38	0.64	0.19	9/16	9/16
5/16	1/4	D-IME5-4	1.17	0.84	1.01	0.56	0.64	0.25	11/16	11/16
3/8	1/8	D-IME6-2	1.20	0.91	0.82	0.38	0.66	0.19	5/8	5/8
3/8	1/4	D-IME6-4	1.20	0.91	1.01	0.56	0.66	0.28	5/8	5/8
3/8	3/8	D-IME6-6	1.26	0.94	1.13	0.56	0.66	0.28	11/16	11/16
3/8	1/2	D-IME6-8	1.32	1.02	1.31	0.75	0.66	0.28	13/16	13/16
3/8	3/4	D-IME6-12	1.45	1.17	1.50	0.75	0.66	0.28	1-1/16	1-1/16
1/2	1/4	D-IME8-4	1.42	1.03	1.12	0.56	0.90	0.28	13/16	13/16
1/2	3/8	D-IME8-6	1.42	1.03	1.12	0.56	0.90	0.38	13/16	13/16
1/2	1/2	D-IME8-8	1.43	1.03	1.31	0.75	0.90	0.41	13/16	13/16
1/2	3/4	D-IME8-12	1.53	1.17	1.50	0.75	0.90	0.41	1-1/16	1-1/16
5/8	3/8	D-IME10-6	1.43	1.10	1.25	0.56	0.96	0.38	15/16	15/16
5/8	1/2	D-IME10-8	1.43	1.10	1.31	0.75	0.96	0.47	15/16	15/16
5/8	3/4	D-IME10-12	1.56	1.17	1.50	0.75	0.96	0.50	1-1/16	1-1/16
3/4	1/2	D-IME12-8	1.56	1.17	1.50	0.75	0.96	0.47	1-1/16	1-1/16
3/4	3/4	D-IME12-12	1.56	1.17	1.50	0.75	0.96	0.62	1-1/16	1-1/16
1	3/4	D-IME16-12	1.94	1.45	1.65	0.75	1.21	0.62	1-3/8	1-3/8
1	1	D-IME16-16	1.94	1.45	1.84	0.94	1.21	0.88	1-3/8	1-3/8

## MALE ELBOW

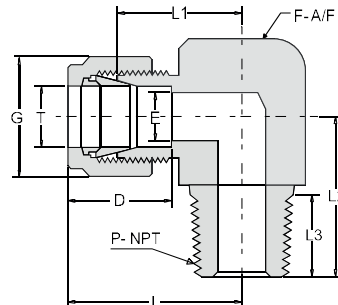

T TUBE O.D.	P-NPT MALE THREAD	PART NO.	L	L1	L2	L3	D	E	F Wrench Pad	G Hex Flat
-------------------	-------------------------	----------	---	----	----	----	---	---	--------------------	------------------

### DIMENSION IN MILLIMETERS

6	1/8	D-MME6-2	27.0	19.6	18.8	9.7	15.3	4.8	1/2	14
6	1/4	D-MME6-4	27.0	19.6	23.4	14.2	15.3	4.8	1/2	14
6	3/8	D-MME6-4	29.8	22.4	26.2	14.2	15.3	4.8	11/16	14
6	1/2	D-MME6-8	31.8	24.4	33.0	19.0	15.3	4.8	13/16	14
8	1/8	D-MME8-2	28.8	21.3	19.8	9.7	16.2	4.8	9/16	16
8	1/4	D-MME8-4	28.8	21.3	24.4	14.2	16.2	6.4	9/16	16
8	3/8	D-MME8-6	30.6	23.1	26.2	14.2	16.2	6.4	11/16	16
8	1/2	D-MME8-8	32.7	25.1	33.0	19.1	16.2	6.4	13/16	16
10	1/8	D-MME10-2	31.5	23.9	21.6	9.7	17.2	4.8	11/16	19
10	1/4	D-MME10-4	31.5	23.9	26.2	14.2	17.2	7.1	11/16	19
10	3/8	D-MME10-6	31.5	23.9	26.2	14.2	17.2	7.9	11/16	19
10	1/2	D-MME10-8	33.5	25.9	33.0	19.0	17.2	7.9	13/16	19
12	1/4	D-MME12-4	36.0	25.9	28.2	14.2	22.8	7.1	13/16	22
12	3/8	D-MME12-6	36.0	25.9	28.2	14.2	22.8	9.5	13/16	22
12	1/2	D-MME12-8	36.0	25.9	33.0	19.0	22.8	9.5	13/16	22
12	3/4	D-MME12-12	39.8	29.7	36.8	19.0	22.8	9.5	1-1/16	22
15	1/2	D-MME15-8	38.0	27.9	35.1	19.0	24.4	11.9	15/16	25
16	3/8	D-MME16-6	38.0	27.9	30.2	14.2	24.4	9.5	15/16	25
16	1/2	D-MME16-8	38.0	27.9	35.1	19.0	24.4	11.9	15/16	25
16	3/4	D-MME16-12	39.8	29.9	36.8	19.0	24.4	12.7	1-1/16	25
18	1/2	D-MME18-8	39.8	29.7	36.8	19.0	24.4	11.9	1-1/16	30
18	3/4	D-MME18-12	39.8	29.7	36.8	19.0	24.4	15.1	1-1/16	30
20	1/2	D-MME20-8	44.6	34.5	41.7	19.0	26.0	11.9	1-3/8	32
20	3/4	D-MME20-12	44.6	34.5	41.7	19.0	26.0	15.9	1-3/8	32
22	3/4	D-MME22-12	44.6	34.5	41.7	19.0	26.0	15.9	1-3/8	32
25	3/4	D-MME25-12	49.1	36.8	41.7	19.0	31.3	15.9	1-3/8	38
25	1	D-MME25-16	49.1	36.8	46.50	23.9	31.3	21.8	1-3/8	38

## MALE BRANCH TEE

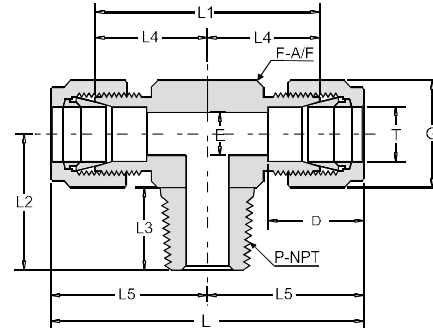

T TUBE O.D.	P-NPT MALE THREAD	PART NO.	L	L1	L2	L3	L4	L5	D	E	F Wrench Pad	G Hex Flat
<b>DIMENSION IN INCHES</b>												
1/8	1/8	D-IMBT2-2	1.86	1.34	0.70	0.38	0.67	0.92	0.50	0.09	7/16	7/16
1/8	1/8	D-IMBT2-4	1.94	1.42	0.92	0.56	0.71	0.98	0.50	0.09	1/2	7/16
1/4	1/4	D-IMBT4-2	2.12	1.54	0.74	0.38	0.77	1.06	0.60	0.19	1/2	1/2
1/4	1/4	D-IMBT4-4	2.12	1.54	0.92	0.56	0.77	1.07	0.60	0.19	1/2	9/16
5/16	5/16	D-IMBT5-2	2.34	1.76	0.82	0.38	0.88	1.17	0.64	0.19	5/8	9/16
3/8	3/8	D-IMBT6-4	2.40	1.82	1.00	0.56	0.91	1.20	0.66	0.28	5/8	5/8
3/8	3/8	D-IMBT6-6	2.62	2.04	1.11	0.56	1.02	1.31	0.66	0.28	13/16	11/16
1/2	1/2	D-IMBT8-6	2.84	2.04	1.11	0.56	1.02	1.42	0.90	0.38	13/16	7/8
1/2	1/2	D-IMBT8-8	2.84	2.04	1.30	0.75	1.02	1.43	0.90	0.41	13/16	7/8
5/8	5/8	D-IMBT10-8	2.84	2.26	1.41	0.75	1.13	1.43	0.96	0.47	1	1
3/4	3/4	D-IMBT12-12	3.12	2.34	1.45	0.75	1.17	1.56	0.96	0.62	1-1/16	1-1/8

T TUBE O.D.	P-NPT MALE THREAD	PART NO.	L	L1	L2	L3	L4	L5	D	E	F Wrench Pad	G Hex Flat
<b>DIMENSION IN MILLIMETERS</b>												
6	1/8	D-MMBT6-2	53.9	39.1	18.8	9.70	19.6	27.0	15.3	4.8	1/2	14
8	1/8	D-MMBT8-2	59.7	44.7	20.8	9.70	22.4	29.9	16.2	4.8	5/8	16
10	1/4	D-MMBT10-4	67.0	51.8	28.2	14.2	25.9	33.5	17.2	7.1	13/16	19
12	3/8	D-MMBT12-6	72.0	51.8	28.2	14.2	25.9	36.0	22.8	9.5	13/16	22
16	1/2	D-MMBT16-8	77.6	57.4	35.8	19.1	28.7	38.8	24.4	11.9	1	25

## MALE RUN TEE

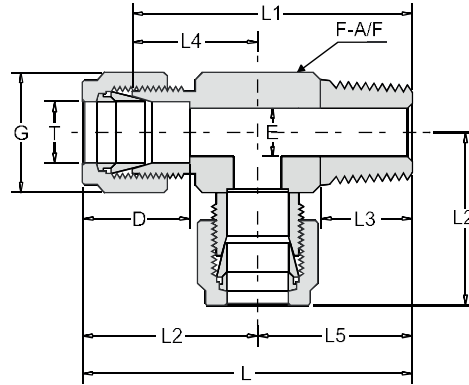
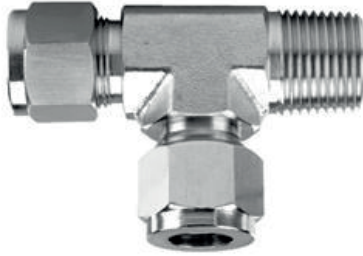

T TUBE O.D.	P-NPT MALE THREAD	PART NO.	L	L1	L2	L3	L4	L5	D	E	F Wrench Pad	G Hex Flat
-------------------	-------------------------	----------	---	----	----	----	----	----	---	---	--------------------	------------------

### DIMENSION IN INCHES

1/8	1/8	D-IMRT2-2	1.63	1.37	0.93	0.38	0.67	0.70	0.50	0.09	7/16	7/16
1/8	1/4	D-IMRT2-4	1.89	1.63	0.98	0.56	0.71	0.92	0.50	0.09	1/2	7/16
1/4	1/8	D-IMRT4-2	1.80	1.51	1.06	0.38	0.77	0.74	0.60	0.19	1/2	9/16
1/4	1/4	D-IMRT4-4	1.98	1.69	1.07	0.56	0.77	0.92	0.60	0.19	1/2	9/16
5/16	1/8	D-IMRT5-2	1.99	1.70	1.17	0.38	0.88	0.82	0.64	0.19	5/8	5/8
3/8	1/4	D-IMRT6-4	2.20	1.91	1.20	0.56	0.91	1.00	0.66	0.28	5/8	11/16
3/8	3/8	D-IMRT6-6	2.42	2.13	1.31	0.56	1.02	1.11	0.66	0.28	5/8	11/16
1/2	3/8	D-IMRT8-6	2.53	2.13	1.42	0.56	1.02	1.11	0.90	0.38	13/16	7/8
1/2	1/2	D-IMRT8-8	2.72	2.32	1.43	0.75	1.02	1.30	0.90	0.41	13/16	7/8
5/8	1/2	D-IMRT10-8	2.88	2.48	1.43	0.75	1.10	1.38	0.96	0.47	15/16	1
3/4	3/4	D-IMRT12-12	3.02	2.62	1.56	0.75	1.17	1.45	0.96	0.62	1-1/16	1-1/8

T TUBE O.D.	P-NPT MALE THREAD	PART NO.	L	L1	L2	L3	L4	L5	D	E	F Wrench Pad	G Hex Flat
-------------------	-------------------------	----------	---	----	----	----	----	----	---	---	--------------------	------------------

### DIMENSION IN MILLIMETERS

6	1/8	D-MMRT6-2	45.8	38.4	27.0	9.70	19.6	18.0	15.3	4.8	1/2	14
6	1/4	D-MMRT6-4	50.3	42.9	27.0	14.2	19.6	23.4	15.3	4.8	1/2	14
8	1/4	D-MMRT8-4	55.3	47.8	29.9	14.2	22.4	25.4	16.2	6.4	5/8	16
12	1/4	D-MMRT12-4	64.2	54.1	36.0	14.2	25.9	28.2	22.8	7.1	13/16	22
12	1/2	D-MMRT12-8	69.0	58.9	36.0	19.0	25.9	33.0	22.8	9.5	13/16	22
16	1/2	D-MMRT16-16	73.1	63.0	38.0	19.0	27.9	35.0	24.4	12.7	15/16	25

## FEMALE CONNECTOR

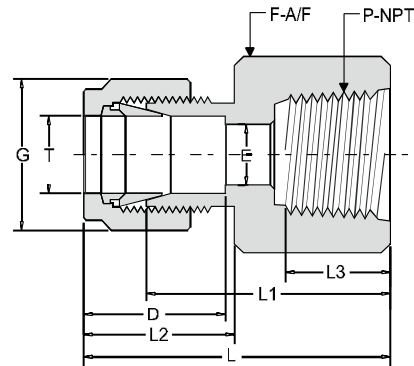
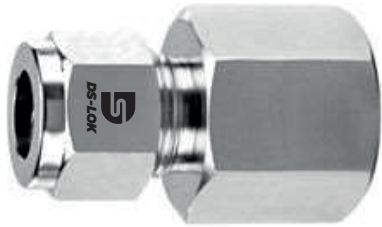

T TUBE O.D.	P-NPT MALE THREAD	PART NO.	L	L1	L2	L3	D	E	F HEX FLAT	G HEX FLAT
<b>DIMENSION IN INCHES</b>										
1/8	1/8	D-IFC2-2	1.13	0.87	0.60	0.41	0.50	0.09	9/16	7/16
1/8	1/4	D-IFC2-4	1.32	1.06	0.60	0.59	0.50	0.09	3/4	7/16
1/4	1/8	D-IFC4-2	1.23	0.94	0.70	0.38	0.60	0.19	9/16	9/16
1/4	1/4	D-IFC4-4	1.41	1.12	0.70	0.59	0.60	0.19	3/4	9/16
1/4	3/8	D-IFC4-6	1.48	1.19	0.70	0.59	0.60	0.19	7/8	9/16
1/4	1/2	D-IFC4-8	1.67	1.38	0.70	0.78	0.60	0.19	1-1/16	9/16
5/16	1/8	D-IFC5-2	1.26	0.97	0.73	0.41	0.64	0.25	9/16	5/8
5/16	1/4	D-IFC5-4	1.45	1.16	0.73	0.59	0.64	0.25	3/4	5/8
3/8	1/8	D-IFC6-2	1.29	1.00	0.76	0.41	0.66	0.28	5/8	11/16
3/8	1/4	D-IFC6-4	1.48	1.19	0.76	0.59	0.66	0.28	3/4	11/16
3/8	3/8	D-IFC6-6	1.54	1.25	0.76	0.59	0.66	0.28	7/8	11/16
3/8	1/2	D-IFC6-8	1.73	1.44	0.76	0.78	0.66	0.28	1-1/16	11/16
3/8	3/4	D-IFC6-12	1.88	1.59	0.76	0.78	0.66	0.28	1-5/16	11/16
1/2	1/4	D-IFC8-4	1.59	1.19	0.86	0.59	0.90	0.41	13/16	7/8
1/2	3/8	D-IFC8-6	1.65	1.25	0.86	0.59	0.90	0.41	7/8	7/8
1/2	1/2	D-IFC8-8	1.84	1.44	0.86	0.78	0.90	0.41	1-1/16	7/8
1/2	3/4	D-IFC8-12	1.90	1.50	0.86	0.81	0.90	0.41	1-5/16	7/8
5/8	3/8	D-IFC10-6	1.65	1.25	0.86	0.59	0.96	0.50	15/16	1
5/8	1/2	D-IFC10-8	1.84	1.44	0.86	0.81	0.96	0.50	1-1/16	1
5/8	3/4	D-IFC10-12	1.90	1.50	0.86	0.78	0.96	0.50	1-5/16	1
3/4	1/2	D-IFC12-8	1.84	1.62	0.86	0.81	0.96	0.62	1-1/16	1-1/8
3/4	3/4	D-IFC12-12	1.90	1.97	0.86	0.81	0.96	0.62	1-5/16	1-1/8
1	3/4	D-IFC16-12	2.10	1.62	1.05	0.81	1.23	0.88	1-3/8	1-1/2
1	1	D-IFC16-16	2.45	1.97	1.05	1.00	1.23	0.88	1-5/8	1-1/2

## FEMALE CONNECTOR

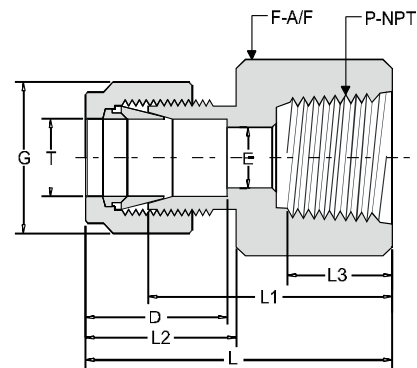

T TUBE O.D.	P-NPT MALE THREAD	PART NO.	L	L1	L2	L3	D	E	F HEX FLAT	G HEX FLAT
-------------------	-------------------------	----------	---	----	----	----	---	---	------------------	------------------

### DIMENSION IN MILLIMETERS

6	1/8	D-MFC6-2	31.3	23.9	17.7	10.4	15.3	4.8	14	14
6	1/4	D-MFC6-4	35.8	28.4	17.7	15.0	15.3	4.8	19	14
6	3/8	D-MFC6-6	37.7	30.2	17.7	15.0	15.3	4.8	22	14
6	1/2	D-MFC6-8	42.5	35.1	17.7	19.8	15.3	4.8	27	14
8	1/8	D-MFC8-2	32.1	24.6	18.6	10.4	16.2	6.4	15	16
8	1/4	D-MFC8-4	37.0	29.5	18.6	15.0	16.2	6.4	19	16
8	3/8	D-MFC8-6	38.5	31.0	18.6	15.0	16.2	6.4	22	16
10	1/4	D-MFC10-4	37.8	30.2	19.5	15.0	17.2	7.9	19	19
10	3/8	D-MFC10-6	39.4	31.8	19.5	15.0	17.2	7.9	22	19
10	1/2	D-MFC10-8	44.2	36.6	19.5	19.8	17.2	7.9	27	19
12	1/4	D-MFC12-4	40.3	30.2	22.0	15.0	22.8	9.5	22	22
12	3/8	D-MFC12-6	41.9	31.8	22.0	19.5	22.8	9.5	22	22
12	1/2	D-MFC12-8	46.7	36.6	22.0	19.8	22.9	9.5	27	22
16	1/2	D-MFC16-8	46.9	36.8	22.0	19.8	24.4	12.7	27	25
20	1/2	D-MFC20-8	47.9	37.8	22.0	19.8	26.0	15.9	30	32
20	3/4	D-MFC20-12	49.7	39.6	22.0	20.6	26.0	15.9	35	32
22	3/4	D-MFC22-12	49.7	39.6	22.0	20.6	26.0	18.3	35	32
25	3/4	D-MFC25-12	53.6	41.1	26.5	20.6	31.3	21.8	35	38
25	1	D-MFC25-16	62.3	50.0	26.5	25.4	31.3	21.8	41	38



## BULK HEAD FEMALE CONNECT

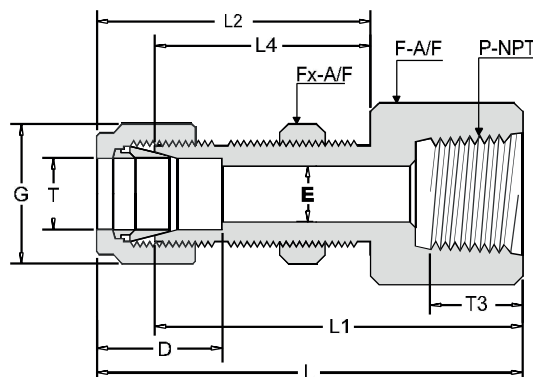

T TUBE O.D.	P-NPT FEMALE THREAD	PART NO.	L	L1	L2	L3	L4	D	E	F HEX FLAT	Fx HEX FLAT	G HEX FLAT	PANEL HOLE SIZE	MAX. PANEL THICK
-------------------	---------------------------	----------	---	----	----	----	----	---	---	------------------	-------------------	------------------	-----------------------	------------------------

DIMENSION IN INCHES

1/8	1/8	D-IMC2-2	1.76	1.50	1.23	0.41	0.97	0.50	0.09	9/16	9/16	7/16	21/64	0.50
1/4	1/8	D-IMC4-2	1.85	1.56	1.31	0.41	1.03	0.60	0.19	5/8	5/8	9/16	29/64	0.40
1/4	1/4	D-IMC4-4	2.04	1.75	1.31	0.59	1.03	0.60	0.19	3/4	5/8	9/16	29/64	0.40
3/8	1/4	D-IMC6-4	2.17	1.88	1.44	0.59	1.16	0.66	0.28	3/4	3/4	1/16	37/64	0.44
1/2	3/8	D-IMC8-6	2.43	2.03	1.65	0.59	1.25	0.90	0.41	15/16	15/16	7/8	49/64	0.50
1/2	1/2	D-IMC8-8	2.62	2.22	1.65	0.78	1.25	0.90	0.41	1-1/16	15/16	7/8	49/64	0.50

T TUBE O.D.	P-NPT FEMALE THREAD	PART NO.	L	L1	L2	L3	L4	D	E	F HEX FLAT	Fx HEX FLAT	G HEX FLAT	PANEL HOLE SIZE	MAX. PANEL THICK
-------------------	---------------------------	----------	---	----	----	----	----	---	---	------------------	-------------------	------------------	-----------------------	------------------------

DIMENSION IN MILLIMETERS

6	1/4	D-IMC6-4	51.8	44.4	33.6	15.0	26.2	15.3	4.80	19	16	14	11.50	10.20
12	1/2	D-IMC12-8	66.5	56.4	41.9	19.8	31.8	22.8	9.50	27	24	22	19.50	12.70

## FEMALE ELBOW

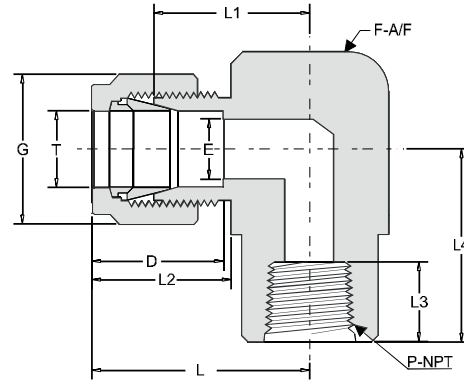

T TUBE O.D.	P-NPT FEMALE THREAD	PART NO.	L	L1	L2	L3	L4	D	E	F WRENCH PAD	G HEX FLAT
<b>DIMENSION IN INCHES</b>											
1/8	1/8	D-IFE2-2	0.97	0.71	0.60	0.41	0.75	0.50	0.09	1/2	7/16
1/8	1/4	D-IFE2-4	1.08	0.82	0.60	0.59	0.88	0.50	0.09	11/16	7/16
1/4	1/8	D-IFE4-2	1.07	0.77	0.70	0.41	0.75	0.60	0.19	1/2	9/16
1/4	1/4	D-IFE4-4	1.17	0.88	0.70	0.59	0.88	0.60	0.19	11/16	9/16
1/4	3/8	D-IFE4-6	1.25	0.96	0.70	0.59	0.88	0.60	0.19	13/16	9/16
1/4	1/2	D-IFE4-8	1.35	1.07	0.70	0.78	1.12	0.60	0.19	1	9/16
5/16	1/8	D-IFE5-2	1.13	0.84	0.73	0.41	0.75	0.64	0.25	9/16	5/8
5/16	1/4	D-IFE5-4	1.20	0.91	0.73	0.59	0.88	0.64	0.25	11/16	5/8
3/8	1/8	D-IFE6-2	1.20	0.91	0.76	0.41	0.75	0.66	0.28	5/8	11/16
3/8	1/4	D-IFE6-4	1.23	0.94	0.76	0.59	0.88	0.66	0.28	11/16	11/16
3/8	3/8	D-IFE6-6	1.31	1.02	0.76	0.59	0.88	0.66	0.28	13/16	11/16
3/8	1/2	D-IFE6-8	1.42	1.13	0.76	0.78	1.12	0.66	0.28	1	11/16
1/2	1/4	D-IFE8-4	1.42	1.03	0.86	0.59	0.88	0.90	0.41	13/16	7/8
1/2	3/8	D-IFE8-6	1.43	1.03	0.86	0.59	0.88	0.90	0.41	13/16	7/8
1/2	1/2	D-IFE8-8	1.53	1.13	0.86	0.78	1.12	0.90	0.41	1	7/8
5/8	3/8	D-IFE10-6	1.42	1.10	0.86	0.59	0.88	0.96	0.50	15/16	1
5/8	1/2	D-IFE10-8	1.50	1.17	0.86	0.78	1.12	0.96	0.50	1-1/16	1
3/4	1/2	D-IFE12-8	1.57	1.17	0.86	0.78	1.12	0.96	0.62	1-1/16	1-1/8
3/4	3/4	D-IFE12-12	1.76	1.36	0.86	0.81	1.25	0.96	0.62	1-3/8	1-1/8
1	3/4	D-IFE16-12	1.93	1.45	1.04	0.81	1.25	1.23	0.88	1-3/8	1-1/2

## FEMALE ELBOW

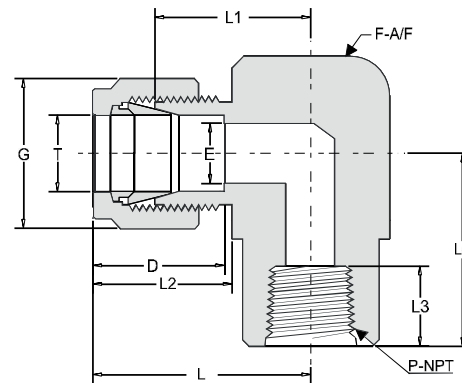

T TUBE O.D.	P-NPT FEMALE THREAD	PART NO.	L	L1	L2	L3	L4	D	E	F WRENCH PAD	G HEX FLAT
-------------------	---------------------------	----------	---	----	----	----	----	---	---	--------------------	------------------

### DIMENSION IN MILLIMETERS

6	1/8	D-MFE6-2	27.0	19.6	17.7	10.4	19.0	15.3	4.8	1/2	14
6	1/4	D-MFE6-4	29.8	22.4	17.7	15.0	22.4	15.3	4.8	11/16	14
8	1/4	D-MFE8-4	30.6	23.1	18.6	10.4	22.4	16.2	6.4	11/16	16
10	1/8	D-MFE10-2	31.5	23.9	19.5	15.0	19.0	17.2	7.9	11/16	19
10	1/4	D-MFE10-8	33.5	25.9	19.5	15.0	22.4	17.2	7.9	13/16	19
12	1/4	D-MFE12-4	36.0	25.9	22.0	15.0	22.4	22.8	9.5	13/16	22
12	1/2	D-MFE12-8	38.8	28.7	22.0	19.8	28.4	22.8	9.5	1	22
16	1/2	D-MFE16-8	39.5	29.7	22.0	19.8	28.4	24.4	12.7	1-1/16	25

## FEMALE BRANCH TEE

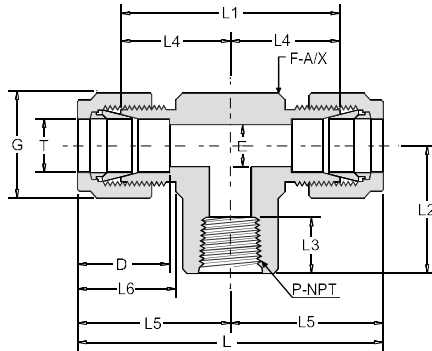

T TUBE O.D.	P-NPT MALE THREAD	PART NO.	L	L1	L2	L3	L4	L5	L6	D	E	F Wrench Pad	G Hex Flat
1/8	1/8	D-IFBT2-2	1.42	1.42	0.75	0.41	0.71	0.97	0.60	0.50	0.09	1/2	7/16
1/4	1/8	D-IFBT4-4	2.12	1.54	0.75	0.41	0.77	1.07	0.70	0.60	0.19	1/2	9/16
1/4	1/4	D-IFBT4-4	2.34	1.76	0.88	0.59	0.88	1.17	0.70	0.66	0.19	11/16	9/16
3/8	1/4	D-IFBT6-4	2.46	1.88	0.88	0.59	0.94	1.23	0.76	0.66	0.28	11/16	11/16
3/8	3/8	D-IFBT6-6	2.62	2.04	0.88	0.59	1.02	1.31	0.76	0.66	0.28	13/16	11/16
3/8	1/2	D-IFBT6-8	2.84	2.26	1.12	0.78	1.13	1.43	0.76	0.90	0.28	1	11/16
1/2	1/4	D-IFBT8-4	2.84	2.04	0.88	0.59	1.02	1.43	0.86	0.90	0.41	13/16	7/8
1/2	3/8	D-IFBT8-6	2.84	2.04	0.88	0.59	1.02	1.43	0.86	0.90	0.41	13/16	7/8
1/2	1/2	D-IFBT8-8	3.06	2.26	1.12	0.78	1.13	1.53	0.86	0.90	0.41	1	7/8
5/8	1/2	D-IFBT10-8	3.06	2.26	1.12	0.78	1.13	1.53	0.86	0.96	0.50	1	1
3/4	3/4	D-IFBT12-12	3.52	2.72	1.25	0.81	1.36	1.76	0.86	0.96	0.62	1-3/8	1-1/8
1	3/4	D-IFBT16-12	3.86	2.90	1.25	0.81	1.45	1.94	1.04	1.23	0.88	1-3/8	1-1/2

T TUBE O.D.	P-NPT MALE THREAD	PART NO.	L	L1	L2	L3	L4	L5	L6	D	E	F Wrench Pad	G Hex Flat
6	1/8	D-MFBT6-2	53.9	39.1	19.6	10.4	19.6	27.0	17.7	15.3	4.8	1/2	14
6	1/4	D-MFBT6-4	59.5	44.7	22.4	15.0	22.4	29.8	17.7	15.3	4.8	11/16	14
8	1/8	D-MFBT8-2	59.7	44.7	19.0	10.4	22.4	29.9	18.6	16.2	6.4	5/8	16
8	1/4	D-MFBT8-4	61.2	46.2	22.4	15.0	23.1	30.6	18.6	16.2	7.4	11/16	16
10	1/4	D-MFBT10-4	67.0	51.8	22.4	15.0	25.9	33.5	19.5	17.2	7.9	13/16	19
12	3/8	D-MFBT12-6	72.0	51.8	22.4	15.0	25.9	36.0	22.0	22.8	9.5	13/16	22
12	1/4	D-MFBT12-4	72.0	51.8	22.4	15.0	25.9	36.0	22.0	22.8	9.5	13/16	22
16	1/2	D-MFBT16-8	77.6	57.4	28.4	19.8	28.7	38.8	22.0	24.4	12.7	1	25

## FEMALE RUN TEE

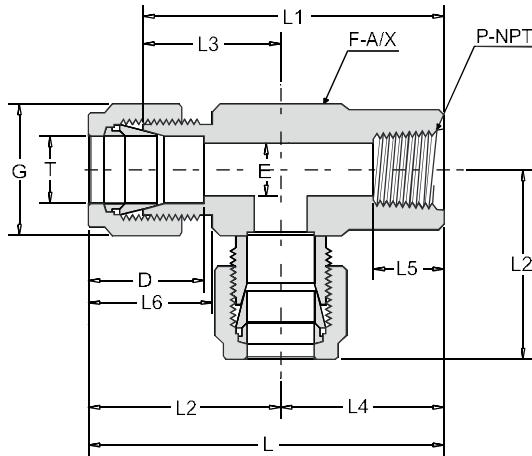

T TUBE O.D.	P-NPT MALE THREAD	PART NO.	L	L1	L2	L3	L4	L5	L6	D	E	F Wrench Pad	G Hex Flat
-------------------	-------------------------	----------	---	----	----	----	----	----	----	---	---	--------------------	------------------

### DIMENSION IN INCHES

1/8	1/8	D-IFRT2-2	1.72	1.46	0.97	0.41	0.71	0.75	0.60	0.50	0.09	1/2	7/16
1/4	1/8	D-IFRT4-2	1.81	1.52	1.01	0.41	0.77	0.75	0.70	0.60	0.19	1/2	9/16
1/4	1/4	D-IFRT4-4	2.05	1.76	1.17	0.59	0.88	0.88	0.70	0.60	0.19	11/16	9/16
3/8	1/4	D-IFRT6-4	2.11	1.82	1.23	0.59	0.94	0.88	0.76	0.66	0.28	11/16	11/16
1/2	3/8	D-IFRT8-6	2.30	1.90	1.42	0.59	1.02	0.88	0.86	0.90	0.41	13/16	7/8
1/2	1/2	D-IFRT8-8	2.69	2.29	1.57	0.78	1.17	1.12	0.86	0.90	0.41	1-1/16	7/8
3/4	3/4	D-IFRT12-12	3.04	2.61	1.76	0.81	1.36	1.25	0.86	0.96	0.61	1-3/8	1-1/8
1	3/4	D-IFRT16-12	3.18	2.70	1.93	0.81	1.45	1.25	1.04	1.23	0.88	1-3/8	1-1/2

T TUBE O.D.	P-NPT MALE THREAD	PART NO.	L	L1	L2	L3	L4	L5	L6	D	E	F Wrench Pad	G Hex Flat
-------------------	-------------------------	----------	---	----	----	----	----	----	----	---	---	--------------------	------------------

### DIMENSION IN MILLIMETERS

6	1/8	D-IFRT6-2	46.0	38.6	27.0	10.4	19.6	19.0	17.7	15.3	4.8	1/2	14
6	1/4	D-IFRT6-4	52.1	44.7	29.8	15.0	22.4	22.4	17.7	15.3	4.8	11/26	14
8	1/8	D-IFRT8-2	48.9	41.4	29.9	10.4	22.4	19.0	18.6	16.2	6.4	5/8	16
10	1/4	D-IFRT10-4	55.9	48.3	33.5	15.0	25.9	22.1	19.5	17.2	7.9	11/16	19
12	1/4	D-IFRT12-4	58.4	48.3	36.0	15.0	25.9	22.4	22.0	22.8	10.3	13/16	22
12	3/8	D-IFRT12-6	58.4	48.3	36.0	15.0	25.9	44.4	22.0	22.8	9.5	13/16	22
16	1/2	D-IFRT16-8	68.2	58.1	39.8	19.8	29.7	28.4	22.0	24.4	12.7	1-1/16	25

## UNION

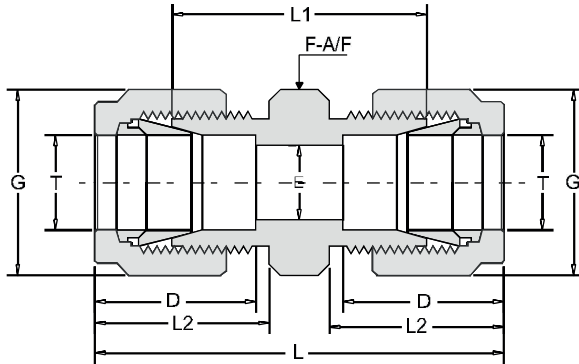

T1 TUBE O.D.	PART NO.	L	L1	L2	D	E	F HEX FLAT	G HEX FLAT
--------------------	----------	---	----	----	---	---	------------------	------------------

DIMENSION IN INCHES

1/8	D-IU2	1.40	0.88	0.60	0.50	0.09	7/16	7/16
1/4	D-IU4	1.61	1.03	0.70	0.60	0.19	1/2	9/16
5/16	D-IU5	1.69	1.11	0.73	0.64	0.25	9/16	5/8
3/8	D-IU6	1.77	1.19	0.76	0.66	0.28	5/8	11/16
1/2	D-IU8	2.02	1.22	0.86	0.90	0.41	13/16	7/8
5/8	D-IU10	2.05	1.25	0.86	0.96	0.50	15/16	1
3/4	D-IU12	2.11	1.31	0.86	0.96	0.61	1-1/16	1-1/8
1	D-IU16	2.55	1.59	1.05	1.02	0.86	1-3/8	1-1/2

T1 TUBE O.D.	PART NO.	L	L1	L2	D	E	F HEX FLAT	G HEX FLAT
--------------------	----------	---	----	----	---	---	------------------	------------------

DIMENSION IN INCHES

6	D-MU6	41.0	26.2	17.7	15.3	4.8	14	14
8	D-MU8	43.2	28.2	18.6	16.2	6.4	15	16
10	D-MU10	46.2	31.0	19.5	17.2	7.9	18	19
12	D-MU12	51.2	31.0	22.0	22.8	9.5	22	22
14	D-MU14	52.0	31.8	22.0	24.4	11.1	24	25
15	D-MU15	52.0	31.8	22.0	24.4	11.9	24	25
16	D-MU16	52.0	31.9	22.0	24.4	12.7	24	25
18	D-MU18	53.5	33.3	22.0	24.4	15.1	27	30
20	D-MU20	55.0	34.8	22.0	26.0	15.9	30	32
22	D-MU22	55.0	34.8	22.0	26.0	18.3	30	32
25	D-MU25	65.0	40.4	26.5	31.3	21.8	35	38



## REDUCING UNION

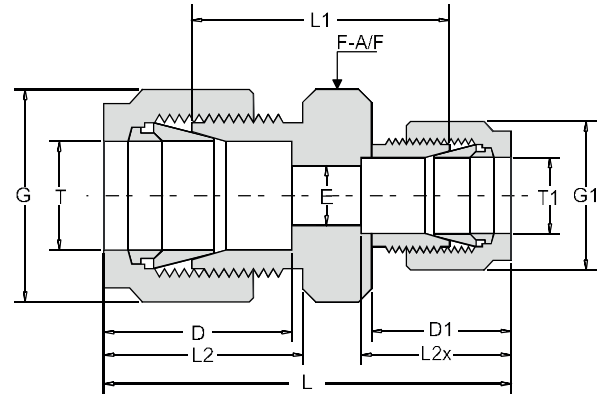

T TUBE O.D.	T1 TUBE O.D.	PART NO.	L	L1	L2	L2x	D	D1	E	F Hex Flat	G Hex Flat	G1 Hex Flat
DIMENSION IN INCHES												
1/4	1/8	D-IRU4-2	1.52	0.97	0.70	0.60	0.60	0.50	0.09	1/2	9/16	7/16
5/16	1/8	D-IRU5-2	1.58	1.03	0.73	0.60	0.64	0.50	0.09	9/16	5/8	7/16
5/16	1/4	D-IRU5-4	1.67	1.08	0.73	0.70	0.64	0.60	0.10	9/16	5/8	9/16
3/8	1/8	D-IRU6-2	1.61	1.06	0.76	0.60	0.66	0.50	0.09	5/8	11/16	7/16
3/8	1/4	D-IRU6-4	1.71	1.13	0.76	0.70	0.66	0.60	0.19	5/8	11/16	9/16
3/8	5/16	D-IRU6-5	1.75	1.16	0.76	0.73	0.66	0.64	0.25	5/8	11/16	5/8
1/2	1/8	D-IRU8-2	1.78	1.09	0.86	0.60	0.90	0.50	0.09	13/16	7/8	7/16
1/2	1/4	D-IRU8-4	1.85	1.16	0.86	0.70	0.90	0.60	0.19	13/16	7/8	9/16
1/2	3/8	D-IRU8-6	1.91	1.22	0.86	0.76	0.90	0.66	0.28	13/16	7/8	11/16
5/8	3/8	D-IRU10-6	1.94	1.25	0.86	0.76	0.96	0.66	0.28	15/16	1	11/16
5/8	1/2	D-IRU10-8	2.05	1.25	0.86	0.86	0.96	0.90	0.41	15/16	1	7/8
3/4	1/4	D-IRU12-4	1.95	1.25	0.86	0.70	0.96	0.60	0.19	1-1/16	1-1/8	1-9/16
3/4	3/8	D-IRU12-6	2.00	1.31	0.86	0.76	0.96	0.66	0.28	1-1/16	1-1/8	1-11/16
3/4	1/2	D-IRU12-8	2.11	1.31	0.86	0.86	0.96	0.90	0.41	1-1/16	1-1/8	1-7/8
3/4	5/8	D-IRU12-10	2.11	1.31	0.86	0.86	0.96	0.96	0.50	1-1/16	1-1/8	1
1	1/2	D-IRU16-8	2.49	1.61	1.05	0.86	1.23	0.90	0.41	1-3/8	1-1/2	1-7/8
1	3/4	D-IRU16-12	2.47	1.59	1.05	0.86	1.23	0.96	0.62	1-3/8	1-1/2	1-1/8

## REDUCING UNION

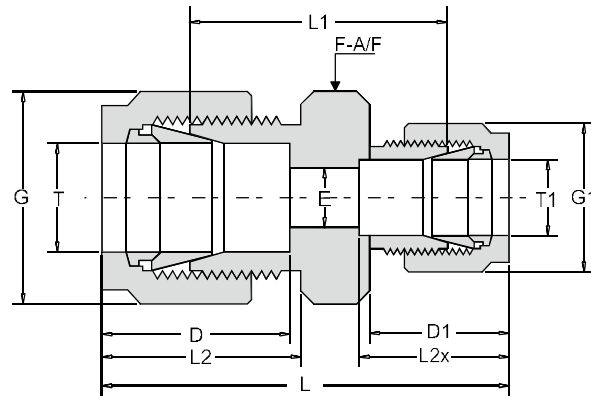
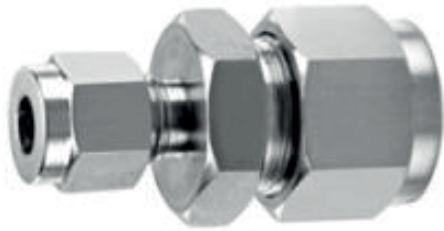

T TUBE O.D.	T1 TUBE O.D.	PART NO.	L	L1	L2	L2x	D	D1	E	F Hex Flat	G Hex Flat	G1 Hex Flat
-------------------	--------------------	----------	---	----	----	-----	---	----	---	------------------	------------------	-------------------

DIMENSION IN MILLIMETERS

8	6	D-MRU8-6	42.3	27.4	18.6	17.7	16.2	15.3	4.8	15	16	14
10	6	D-MRU10-6	44.5	29.5	19.5	17.7	17.2	15.3	4.8	18	19	14
10	8	D-MRU10-8	45.1	30.0	19.5	18.6	17.2	16.2	6.4	18	19	16
12	6	D-MRU12-6	47.0	29.5	22.0	17.7	22.8	15.3	4.8	22	22	14
12	8	D-MRU12-8	47.8	30.2	22.0	18.6	22.8	16.2	6.4	22	22	16
12	10	D-MRU12-10	48.7	31.0	22.0	19.5	22.8	17.2	7.9	22	22	10
16	10	D-MRU16-10	49.5	31.8	22.0	19.5	24.4	17.2	7.9	24	25	10
16	12	D-MRU16-12	52.0	31.8	22.0	22.0	24.4	22.8	9.5	24	25	22
18	12	D-MRU18-12	53.5	33.3	22.0	22.0	24.4	22.8	9.5	27	30	22
25	18	D-MRU25-18	60.0	38.6	26.5	22.0	31.3	24.4	15.1	35	38	30
25	20	D-MRU25-20	62.3	39.9	26.5	22.0	31.3	26.0	15.9	35	38	32

## BULKHEAD UNION

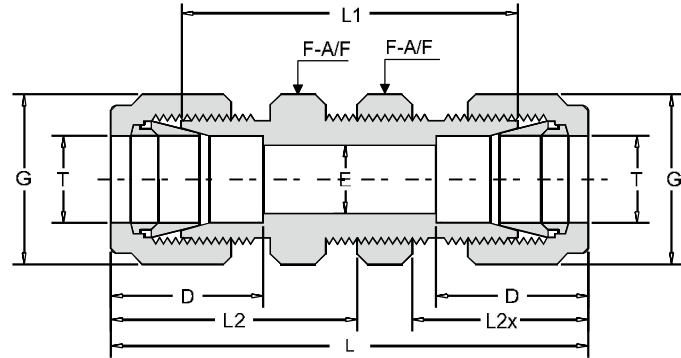

T TUBE O.D.	PART NO.	L	L1	L2	L2x	D	E	F HEX FLAT	G HEX FLAT	PANEL HOLE SIZE	MAX. PANEL THICK
-------------------	----------	---	----	----	-----	---	---	------------------	------------------	-----------------------	------------------------

### DIMENSION IN INCHES

1/8	D-IBU2	2.02	1.50	1.23	0.60	0.50	0.09	1/2	7/16	21/64	1/2
1/4	D-IBU4	2.27	1.69	1.31	0.70	0.60	0.19	5/8	9/16	29/64	17/32
5/16	D-IBU5	2.39	1.81	1.41	0.73	0.64	0.25	11/16	5/8	33/64	9/16
3/8	D-IBU6	2.45	1.87	1.45	0.76	0.66	0.28	3/4	11/16	37/64	9/16
1/2	D-IBU8	2.80	2.00	1.65	0.86	0.90	0.41	15/16	7/8	49/64	19/32
5/8	D-IBU10	2.86	2.06	1.68	0.86	0.96	0.50	1-1/16	1	57/64	19/32
3/4	D-IBU12	3.11	2.31	1.87	0.86	0.96	0.50	1-3/16	1-1/8	1-1/64	25/32
1	D-IBU16	3.77	2.81	2.27	1.04	1.23	0.88	1-5/8	1-1/2	1-21/64	15/16

## BULKHEAD UNION METRIC FITTINGS

T TUBE O.D.	PART NO.	L	L1	L2	L2x	D	E	F HEX FLAT	G HEX FLAT	PANEL HOLE SIZE	MAX. PANEL THICK
-------------------	----------	---	----	----	-----	---	---	------------------	------------------	-----------------------	------------------------

### DIMENSION IN MILLIMETERS

6	D-MBU6	57.7	42.9	33.6	17.7	15.3	4.8	16	14	11.5	10.2
8	D-MBU8	61.0	46.0	36.1	18.6	16.2	6.4	18	16	13.1	11.2
10	D-MBU10	63.7	48.5	37.0	19.5	17.2	7.9	22	19	16.3	11.2
12	D-MBU12	63.7	50.8	41.9	22.0	22.8	7.9	24	22	19.5	12.7
14	D-MBU14	71.0	52.3	42.6	22.0	24.4	9.5	27	25	22.5	12.7
15	D-MBU15	72.5	52.3	42.6	22.0	24.4	11.9	27	25	22.8	12.7
16	D-MBU16	72.5	52.3	42.6	22.0	24.4	12.7	27	25	22.8	12.7
18	D-MBU18	78.9	58.7	47.4	22.0	24.4	15.1	30	30	26.0	16.8
20	D-MBU20	84.5	64.3	53.0	2.2.0	26.0	15.9	35	32	29.0	23.9
32	D-MBU32	128.3	82.3	72.5	41.6	42.0	28.6	41	50	42.5	19.0

## UNION ELBOW

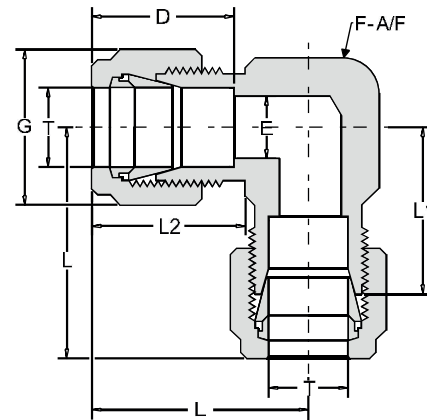

T TUBE O.D.	PART NO.	L	L1	L2	D	E	F WRENCH PAD	G HEX PAD
-------------------	----------	---	----	----	---	---	--------------------	-----------------

DIMENSION IN INCHES

1/8	D-IUE2	0.88	0.62	0.60	0.50	0.09	3/8	7/16
3/16	D-IUE3	1.00	0.74	0.63	0.54	0.09	1/2	1/2
1/4	D-IUE4	1.06	0.77	0.70	0.60	0.20	1/2	9/16
5/16	D-IUE5	1.13	0.84	0.73	0.64	0.25	9/16	5/8
3/8	D-IUE6	1.20	0.91	0.76	0.66	0.28	5/8	11/16
1/2	D-IUE8	1.42	1.02	0.86	0.90	0.41	13/16	7/8
5/8	D-IUE10	1.50	1.10	0.86	0.96	0.50	15/16	1
3/4	D-IUE12	1.57	1.17	0.86	0.96	0.62	1-1/16	1-1/8
7/8	D-IUE14	1.76	1.36	0.86	1.02	0.72	1-3/8	1-1/4
1	D-IUE16	1.93	1.45	1.04	1.23	0.88	1-3/8	1-1/2

T TUBE O.D.	PART NO.	L	L1	L2	D	E	F WRENCH PAD	G HEX PAD
-------------------	----------	---	----	----	---	---	--------------------	-----------------

DIMENSION IN MILLIMETERS

6	D-MUE6	27.0	19.6	17.7	15.3	4.8	1/2	14
8	D-MUE8	28.8	21.3	18.8	16.2	6.4	9/16	16
10	D-MUE10	31.5	23.9	19.5	17.2	7.9	11/16	19
12	D-MUE12	36.0	25.9	22.0	22.8	9.5	13/16	22
14	D-MUE14	38.0	27.9	22.0	24.4	11.1	15/16	25
15	D-MUE15	38.8	27.9	22.0	24.4	11.9	15/16	25
16	D-MUE16	38.0	27.9	22.0	24.4	12.7	1-1/16	25
18	D-MUE18	39.8	29.7	22.0	24.4	15.1	1-3/8	30
20	D-MUE20	44.6	34.5	22.0	26.0	15.9	1-3/8	32
22	D-MUE22	44.6	34.5	22.0	26.0	18.3	1-3/8	32
25	D-MUE25	49.1	36.8	26.5	31.3	21.8	1-3/8	38

## UNION TEE

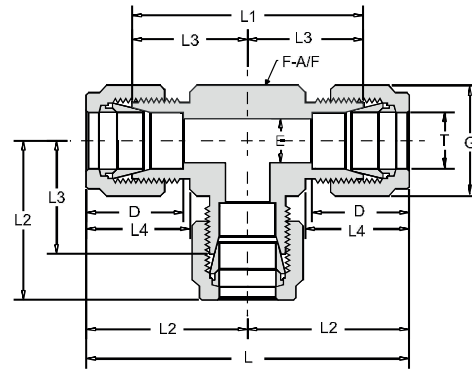

T TUBE O.D.	PART NO.	L	L1	L2	L3	L4	D	E	F WRENCH PAD	G HEX PAD
-------------------	----------	---	----	----	----	----	---	---	--------------------	-----------------

### DIMENSION IN INCHES

1/8	D-IUT2	1.76	0.88	1.24	0.62	0.60	0.50	0.09		7/16
3/16	D-IUT3	1.92	0.96	1.40	0.70	0.63	0.54	0.12		1/2
1/4	D-IUT4	2.12	1.06	1.54	0.77	0.70	0.60	0.19		9/16
5/16	D-IUT5	2.34	1.17	1.76	0.88	0.73	0.64	0.25		5/8
3/8	D-IUT6	2.40	1.20	1.82	0.91	0.76	0.66	0.28		11/16
1/2	D-IUT8	2.84	1.42	2.04	1.02	0.86	0.90	0.41		7/8
5/8	D-IUT10	3.06	1.53	2.26	1.13	0.86	0.96	0.50		1
3/4	D-IUT12	3.12	1.57	2.34	1.17	0.86	0.96	0.62		1-1/8
7/8	D-IUT14	3.52	1.76	2.72	1.36	0.86	1.02	0.72		1-1/4
1	D-IUT16	3.86	1.93	2.90	1.45	1.04	1.23	0.88		1-1/2

T TUBE O.D.	PART NO.	L	L1	L2	L3	L4	D	E	F WRENCH PAD	G HEX PAD
-------------------	----------	---	----	----	----	----	---	---	--------------------	-----------------

### DIMENSION IN MILLIMETERS

6	D-MUT6	53.9	27.0	39.1	19.6	17.7	15.3	4.8	1/2	14
8	D-MUT8	59.7	29.9	44.7	22.4	18.6	16.2	6.4	5/8	16
10	D-MUT10	63.0	31.5	47.8	23.9	19.5	17.2	7.9	11/16	19
12	D-MUT12	72.0	36.0	51.8	25.9	22.0	22.8	9.5	13/16	22
14	D-MUT14	77.6	38.8	57.8	28.7	22.0	24.4	11.1	1	25
15	D-MUT15	77.6	38.8	57.4	28.7	22.0	24.4	11.9	1	25
16	D-MUT16	77.6	38.8	57.4	28.7	22.0	24.4	12.7	1	25
18	D-MUT18	79.5	38.8	59.4	29.7	22.0	24.4	15.1	1-1/6	30
20	D-MUT20	89.3	44.6	69.1	34.5	22.0	26.0	15.9	1-3/8	32
22	D-MUT22	89.3	44.6	69.1	34.5	22.0	26.0	18.3	1-3/8	32
25	D-MUT25	98.3	49.1	73.7	36.8	26.5	31.3	21.8	1-3/8	38

## REDUCING UNION TEES

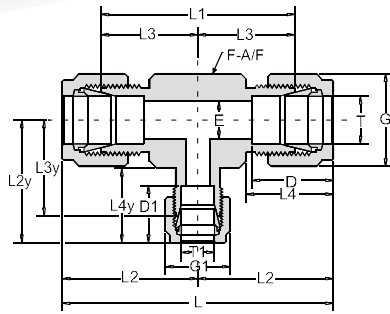

### DIMENSION IN INCHES

3/8	1/4	D-IBRUT6-4	2.40	1.82	1.20	1.14	0.91	0.85	0.76	0.70	0.66	0.60	0.19	5/8	11/16	9/16
1/2	1/4	D-IBRUT8-4	2.84	2.04	1.42	1.25	1.02	0.96	0.86	0.70	0.90	0.60	0.19	13/16	7/8	9/16
1/2	3/8	D-IBRUT8-6	2.84	2.04	1.42	1.31	1.02	1.02	0.86	0.76	0.90	0.66	0.28	13/16	7/8	11/16
5/8	3/8	D-IBRUT10-6	3.06	2.26	1.53	1.42	1.13	1.13	0.86	0.76	0.96	0.66	0.28	1	1	11/16
3/4	3/8	D-IBRUT12-6	3.14	2.34	1.57	1.46	1.17	1.17	0.86	0.76	0.96	0.66	0.28	1-1/8	1-1/8	11/16
3/4	1/2	D-IBRUT12-8	3.14	2.34	1.57	1.57	1.17	1.17	0.86	0.86	0.96	0.90	0.41	1-1/8	1-1/8	7/8
1	3/8	D-IBRUT16-6	3.86	2.90	1.93	1.65	1.45	1.36	1.04	0.76	1.23	0.66	0.28	1-3/8	1-1/4	1-1/16
1	1/2	D-IBRUT16-8	3.86	2.90	1.93	1.76	1.45	1.36	1.04	0.90	1.23	0.86	0.41	1-3/8	1-1/2	7/8

## BULKHEAD REDUCER

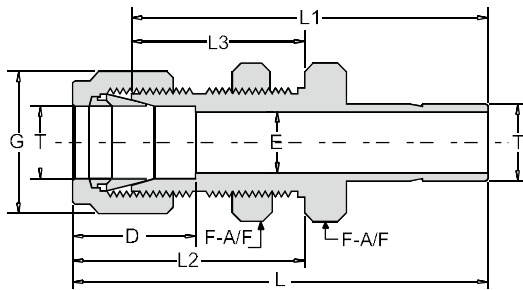

T TUBE O.D.	PART NO.	L	L1	L2	L3	D	E	F HEX FLAT	G HEX FLAT	PANEL HOLE DRILL SIZE	MAXIUM PANEL THICK- NESS
-------------------	----------	---	----	----	----	---	---	------------------	------------------	--------------------------------	-----------------------------------

### DIMENSION IN INCHES

1/4	D-IBR4	2.20	1.91	1.32	1.03	0.60	0.19	5/8	9/16	29/64	0.40
3/8	D-IBR6	2.41	2.12	1.45	1.16	0.66	0.28	3/4	11/16	37/64	0.44
1/2	D-IBR8	2.87	2.47	1.65	1.25	0.90	0.39	15/16	7/8	49/64	0.50
5/8	D-IBR10	2.96	2.56	1.68	1.28	0.96	0.50	1-1/16	1	57/64	0.50
1	D-IBR16	3.95	3.47	2.26	1.78	1.23	0.80	1-5/8	1-1/2	1-21/64	0.75



## REDUCING UNION TEES

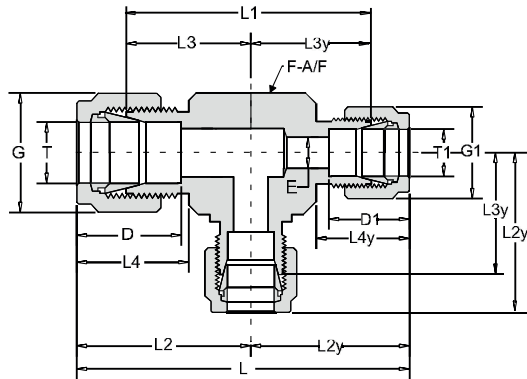

T TUBE O.D.	T1 TUBE O.D.	PART NO.	L	L1	L2	L2y	L3	L3y	L4	L4y	D	D1	E	F WRENCH FLAT	G HEX FLAT	G1 HEX FLAT
-------------------	--------------------	----------	---	----	----	-----	----	-----	----	-----	---	----	---	---------------------	------------------	-------------------

DIMENSION IN INCHES

1/2	3/8	D-IMRUT8-2	2.73	2.04	1.42	1.31	1.02	1.02	0.86	0.76	0.90	0.66	0.28	13/16	7/8	11/16
5/8	3/8	D-IMRUT10-6	2.95	2.26	1.53	1.42	1.13	1.13	0.86	0.76	0.96	0.66	0.28	1	1	11/16
3/4	3/8	D-IMRUT12-6	3.03	3.03	1.57	1.46	1.17	1.17	0.86	0.76	0.96	0.66	0.28	1-1/8	1-1/8	11/16

## REDUCING UNION TEES

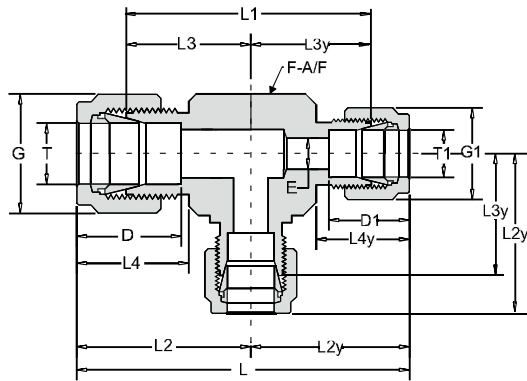

T TUBE O.D.	T1 TUBE O.D.	PART NO.	L	L1	L2	L2y	L2y1	L3	L3y & L3y1	L4	L4y	L4y1	D	D1	D2	E	F WRENCH FLAT	G HEX FLAT	G1 HEX FLAT	G1 HEX FLAT
-------------------	--------------------	----------	---	----	----	-----	------	----	------------------	----	-----	------	---	----	----	---	---------------------	------------------	-------------------	-------------------

DIMENSION IN INCHES

5/8	3/8	D-IMRUT10-8-6	3.06	2.26	1.53	1.53	1.42	1.13	1.13	0.86	0.86	0.76	0.96	0.90	0.66	0.28	1	1	7/8	11/16
3/4	3/8	D-IMRUT12-8-6	3.14	2.34	1.53	1.57	1.46	1.17	1.17	0.86	0.86	0.76	0.96	0.90	0.66	0.28	1-1/16	1-1/8	7/8	11/16
1	3/8	D-IMRUT16-12-6	3.69	2.81	1.57	1.76	1.65	1.45	1.36	1.04	0.86	0.76	1.33	0.96	0.66	0.28	1-3/8	1-1/2	1-1/8	11/16

## UNION CROSS

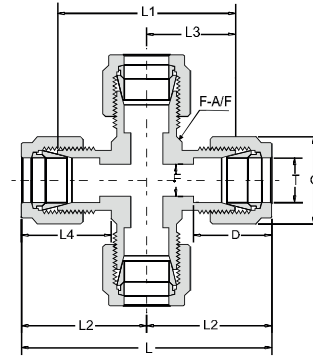

T TUBE O.D.	PART NO.	L	L1	L2	L3	L4	D	E	F WRENCH PAD	G HEX PAD
-------------------	----------	---	----	----	----	----	---	---	--------------------	-----------------

### DIMENSION IN INCHES

1/8	D-IUC2	1.76	1.24	0.88	0.62	0.60	0.50	0.09	3/8	7/16
1/4	D-IUC4	2.12	1.54	1.06	0.77	0.70	0.60	0.19	1/2	9/16
5/16	D-IUC5	2.34	1.76	1.17	0.88	0.73	0.64	0.25	5/8	5/8
3/8	D-IUC6	2.40	1.82	1.20	0.91	0.76	0.66	0.28	5/8	11/16
1/2	D-IUC8	2.84	2.04	1.42	1.02	0.86	0.90	0.41	13/16	7/8
5/8	D-IUC10	3.14	2.34	1.53	1.17	0.86	0.96	0.62	1	1
1	D-IUC16	3.86	2.90	1.93	1.45	1.04	1.23	0.88	1-3/8	1-1/2

T TUBE O.D.	PART NO.	L	L1	L2	L3	L4	D	E	F WRENCH PAD	G HEX PAD
-------------------	----------	---	----	----	----	----	---	---	--------------------	-----------------

### DIMENSION IN MILLIMETERS

6	D-IUC6	53.9	39.1	27.0	19.6	17.7	15.3	4.8	1/2	14
8	D-IUC8	59.7	44.7	29.9	22.4	18.6	16.2	6.4	5/8	16
10	D-IUC10	67.0	51.8	33.5	25.9	19.5	17.2	7.9	13/16	19
12	D-IUC12	72.0	51.8	36.0	25.9	22.0	22.8	9.5	13/16	22
16	D-IUC14	74.0	53.8	37.0	26.9	22.0	24.4	12.7	15/16	25
18	D-IUC18	76.6	56.4	38.3	28.2	22.0	24.4	15.1	1-1/16	30
20	D-IUC20	89.3	69.1	44.6	34.5	22.0	26.0	15.9	1-3/8	32
25	D-IUC25	98.3	73.7	49.1	36.8	26.5	31.3	21.8	1-3/8	38

## AN UNION

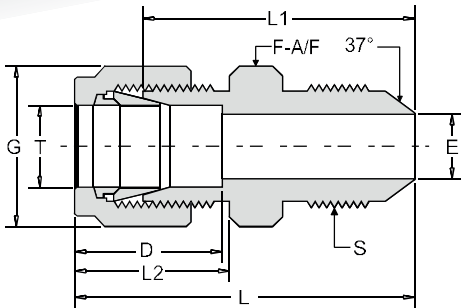

T TUBE O.D.	AN TUBE FLARE SIZE	PART NO.	L	L1	L2	D	E	F HEX FLAT	G HEX FLAT	S
-------------------	-----------------------------	----------	---	----	----	---	---	------------------	------------------	---

DIMENSION IN INCHES

1/8	1/8	D-IANU2-2	1.27	1.01	0.60	0.50	0.06	7/16	7/16	5/16-24UNJF
1/8	1/4	D-IANU2-4	1.38	1.12	0.60	0.50	0.09	1/2	7/16	7/16-20UNJF
1/4	1/4	D-IANU4-4	1.48	1.19	0.70	0.60	0.17	1/2	9/16	7/16-20UNJF
5/16	5/16	D-IANU5-5	1.51	1.22	0.73	0.64	1.23	9/16	5/8	1/2-20UNJF
3/8	1/4	D-IANU6-4	1.56	1.27	0.76	0.66	0.17	5/8	11/16	7/16-20UNJF
3/8	3/8	D-IANU6-6	1.56	1.27	0.76	0.66	0.28	5/8	11/16	9/16-18UNJF
1/2	1/2	D-IANU8-8	1.81	1.41	0.86	0.90	0.39	13/16	7/8	3/4-16UNJF
1	1	D-IANU16-16	2.42	1.94	1.04	1.23	1.84	1-3/8	1-1/2	1-5/16-12UNJ

## AN BULKHEAD UNION

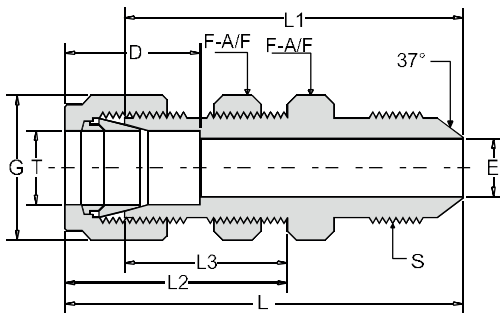

T TUBE O.D.	AN TUBE FLARE SIZE	PART NO.	L	L1	L2	L3	D	E	F	G HEX FLAT	PANEL HOLE SIZE	MAX PANEL THICK	S
-------------------	-----------------------------	----------	---	----	----	----	---	---	---	------------------	-----------------------	-----------------------	---

DIMENSION IN INCHES

1/4	1/4	D-IANBU4-4	2.12	1.83	1.32	1.03	0.60	0.17	5/8	9/16	29/64	17/32	7/16-20UNJF
3/8	3/8	D-IANBU6-6	2.25	1.96	1.45	1.16	0.66	0.28	3/4	11/16	37/64	9/16	9/16-18UNJF
1/2	1/2	D-IANBU8-8	2.59	2.19	1.65	1.25	0.90	0.39	15/16	7/8	49/64	19/32	3/4-16UNJF
3/4	3/4	D-IANBU12-12	3.11	2.71	1.87	1.47	0.96	0.61	1-3/16	1-1/8	1-1/64	25/32	1-1/16-12UNJF
1	1	D-IANBU16-16	3.64	3.16	2.26	1.78	1.23	0.84	1-5/8	1-1/2	1-21/64	15/16	1-5/16-12UNJF

# TUBE SOCKET WELD UNION

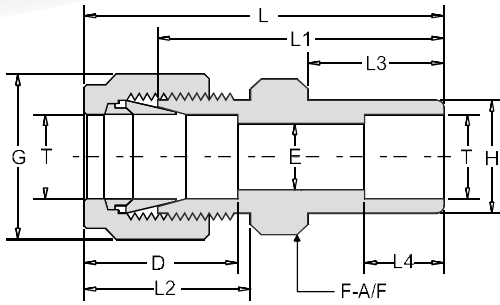

T TUBE O.D.	PART NO.	L	L1	L2	L3	L4	D	E	F HEX Flat	G HEX Flat	H
-------------------	----------	---	----	----	----	----	---	---	------------------	------------------	---

DIMENSION IN INCHES

1/8	D-ITSWU2	1.14	0.60	0.88	0.34	0.25	0.50	0.09	7/16	7/16	0.31
1/4	D-ITSWU4	1.32	0.70	1.03	0.41	0.31	0.60	1.19	1/2	9/16	0.44
3/8	D-ITSWU6	1.48	0.76	1.19	0.47	0.38	0.66	0.28	5/8	11/16	0.62
1/2	D-ITSWU8	1.62	0.86	1.22	0.47	0.50	0.90	0.41	13/16	7/8	0.72
3/4	D-ITSWU12	1.71	0.86	1.31	0.47	0.56	0.96	0.62	1-1/16	1-1/8	1.05
1	D-ITSWU16	2.07	1.04	1.59	0.56	0.75	1.23	0.88	1-3/8	1-1/2	1.31

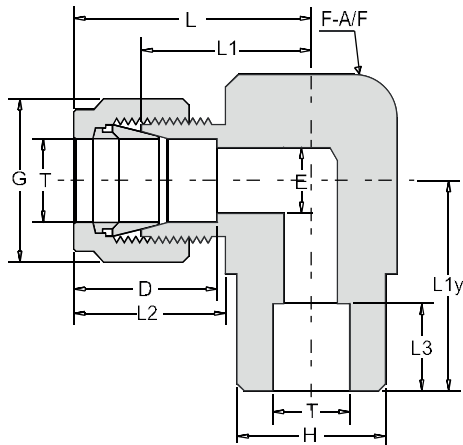

T TUBE O.D.	PART NO.	L	L1	L1y	L2	L3	D	E	F Wrench Pad	G HEX Flat	H
-------------------	----------	---	----	-----	----	----	---	---	--------------------	------------------	---

DIMENSION IN INCHES

1/4	D-ITSWE4	1.06	0.77	0.77	0.70	0.31	0.60	0.19	1/2	9/16	0.50
3/8	D-ITSWE6	1.20	0.91	0.91	0.76	0.38	0.66	0.28	5/8	11/16	0.62
1/2	D-ITSWE8	1.42	1.02	1.02	0.86	0.50	0.90	0.41	13/16	7/8	0.81
3/4	D-ITSWE12	1.57	1.17	1.17	0.86	0.56	0.96	0.61	1-1/16	1-1/8	1.06
1	D-ITSWE16	1.93	1.45	1.45	1.04	0.75	1.23	0.88	1-3/8	1-1/2	1.38

## MALE PIPE WELD CONNEC

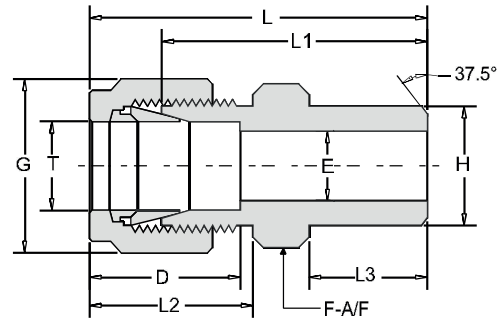
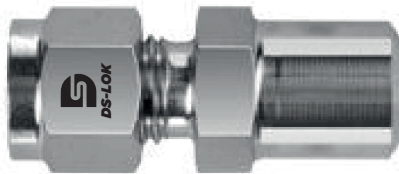

T TUBE O.D.	MALE PIPE WELD SIZE	PART NO.	L	L1	L2	L3	D	E	F HEX FLAT	G HEX FLAT	H
DIMENSION IN INCHES											
1/8	1/8	D-IMPWC2-2	1.20	0.94	0.60	0.38	0.50	0.09	7/16	7/16	0.40
1/4	1/8	D-IMPWC4-2	1.29	1.00	0.70	0.38	0.60	0.19	1/2	9/16	0.40
1/4	1/4	D-IMPWC4-4	1.49	1.20	0.70	0.56	0.60	0.19	9/16	9/16	0.54
5/16	1/8	D-IMPWC5-2	1.34	1.05	0.73	0.38	0.64	0.20	9/16	5/8	0.40
5/16	1/4	D-IMPWC5-2	1.52	1.23	0.73	0.56	0.64	0.25	9/16	5/8	0.54
3/8	1/4	D-IMPWC6-4	1.57	1.28	0.76	0.56	0.66	0.28	5/8	11/16	0.54
3/8	3/8	D-IMPWC6-6	1.57	1.28	0.76	0.56	0.66	0.28	11/16	11/16	0.67
3/8	1/2	D-IMPWC6-8	1.82	1.53	0.76	0.75	0.66	0.28	7/8	11/16	0.84
1/2	3/8	D-IMPWC8-6	1.71	1.31	0.86	0.56	0.90	0.41	13/16	7/8	0.67
1/2	1/2	D-IMPWC8-8	1.93	1.53	0.86	0.75	0.90	0.41	7/8	7/8	0.84
1/2	3/4	D-IMPWC8-12	1.99	1.59	0.87	0.75	0.90	0.41	1-1/16	7/8	1.05
5/8	1/2	D-IMPWC10-8	1.93	1.53	0.86	0.75	0.96	0.50	15/16	1	0.84
3/4	3/4	D-IMPWC12-12	1.99	1.59	0.86	0.75	0.96	0.62	1-1/16	1-1/8	1.05
1	1	D-IMPWC16-16	2.45	1.97	1.04	0.94	1.23	0.88	1-3/8	1-1/2	1.31

## MALE PIPE WELD CONNECTOR

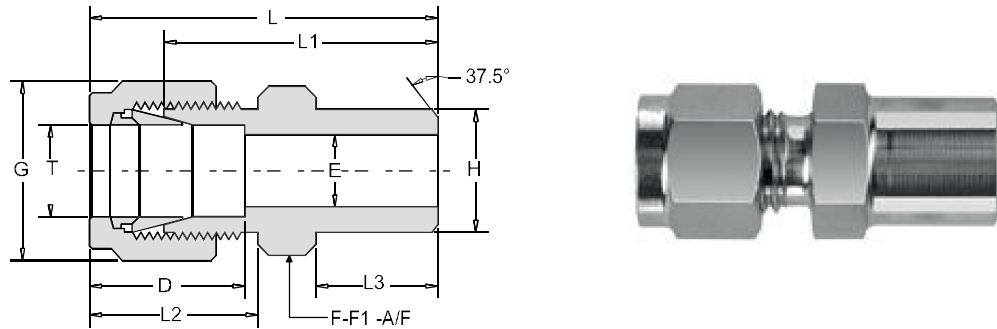

	MALE PIPE WELD SIZE	PART NO.	L	L1	L2	L3	D	E	F HEX FLAT	F1	G HEX FLAT	H
--	---------------------	----------	---	----	----	----	---	---	------------------	----	------------------	---

### DIMENSION IN MILLIMETERS

4	1/8	D-MMPWC4-2	31.2	24.6	16.1	9.7	13.7	2.4	12	1/2	12	10.3
6	1/8	D-MMPWC6-2	32.8	25.4	17.7	9.7	15.3	4.8	14	1/2	14	10.3
6	1/4	D-MMPWC6-4	37.9	30.5	17.7	14.2	15.3	4.8	14	9/16	14	13.7
8	1/8	D-MMPWC8-2	34.2	26.7	18.6	9.7	16.2	5.1	15	9/16	16	10.3
8	1/4	D-MMPWC8-4	38.7	31.2	18.6	14.2	16.2	6.4	15	9/16	16	13.7
8	1/2	D-MMPWC8-4	45.6	38.1	18.6	19.0	16.2	6.4	22	7/8	16	21.3
10	1/4	D-MMPWC10-4	40.9	33.3	19.5	14.2	17.2	7.1	18	11/16	19	13.7
10	3/8	D-MMPWC10-6	40.9	33.3	19.5	14.2	17.2	7.9	18	11/16	19	17.1
10	1/2	D-MMPWC10-8	46.5	38.9	19.5	19.0	17.2	7.9	22	7/8	19	21.3
12	1/4	D-MMPWC12-4	43.4	33.3	22.2	14.2	22.8	7.1	22	13/16	22	13.7
12	3/8	D-MMPWC12-6	43.4	33.3	22.2	14.2	22.8	9.5	22	13/16	22	17.1
12	1/2	D-MMPWC12-8	49.0	38.9	22.2	19.0	22.8	9.5	22	7/8	22	21.3
14	3/8	D-MMPWC14-6	44.1	34.0	22.2	14.2	24.4	10.3	24	15/16	25	17.1
15	1/2	D-MMPWC15-8	49.0	38.9	22.2	19.0	24.4	11.9	24	15/16	25	21.3
16	1/2	D-MMPWC16-8	49.0	38.9	22.2	19.0	24.4	12.7	24	15/16	25	21.3
18	1/2	D-MMPWC18-8	50.5	40.4	22.2	19.0	24.4	13.5	27	1-1/16	30	21.3
32	1-1/4	D-MMPWC32-20	79.6	56.6	41.6	23.2	42.0	28.6	46	46	50	42.2

## REDUCER

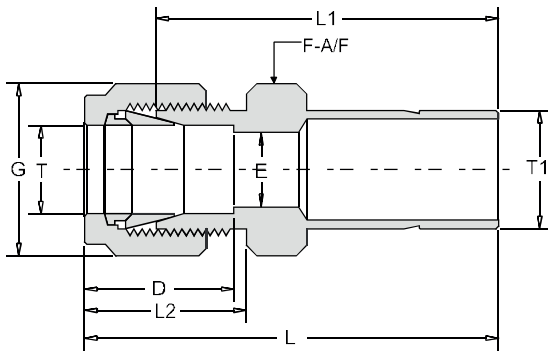

T TUBE O.D.	T1 TUBE O.D.	PART NO.	L	L1	L2	D	E	F HEX FLAT	G HEX FLAT
-------------------	--------------------	----------	---	----	----	---	---	------------------	------------------

### DIMENSION IN INCHES

1/8	1/8	D-IR2-2	1.32	1.06	0.60	0.50	0.08	7/16	7/16
1/8	1/4	D-IR2-4	1.42	1.16	0.60	0.50	0.09	7/16	7/16
1/4	1/8	D-IR4-2	1.45	1.16	0.70	0.54	0.08	1/2	9/16
1/4	1/4	D-IR4-4	1.54	1.25	0.70	0.54	0.19	1/2	9/16
1/4	3/8	D-IR4-6	1.60	1.31	0.70	0.60	0.19	1/2	9/16
1/4	1/2	D-IR4-8	1.82	1.53	0.70	0.60	0.19	9/16	9/16
3/8	1/4	D-IR6-4	1.63	1.34	0.76	0.66	0.19	5/8	11/16
3/8	3/8	D-IR6-6	1.70	1.41	0.76	0.66	0.28	5/8	11/16
3/8	1/2	D-IR6-8	1.91	1.62	0.76	0.66	0.28	5/8	11/16
1/2	1/4	D-IR8-4	1.77	1.37	0.86	0.90	0.19	13/16	7/8
1/2	3/8	D-IR8-6	1.84	1.44	0.86	0.90	0.28	13/16	7/8
1/2	3/4	D-IR8-12	2.12	1.72	0.86	0.90	0.39	13/16	7/8
5/8	3/4	D-IR10-12	2.15	1.75	0.86	0.96	0.50	15/16	1
5/8	7/8	D-IR10-14	2.21	1.81	0.86	0.96	0.50	15/16	1
5/8	1	D-IR10-16	2.40	2.00	0.86	0.96	0.50	1-1/16	1
3/4	1/2	D-IR12-8	2.15	1.75	0.86	0.96	0.39	1-1/16	1-1/8
3/4	1	D-IR12-16	2.46	2.06	0.86	0.96	0.62	1-1/16	1-1/8
1	1-1/4	D-IR16-20	3.17	2.69	1.04	1.23	0.88	1-3/8	1-1/2
1	1-1/2	D-IR16-24	3.51	3.03	1.04	1.23	0.88	1-5/8	1-1/2
1	2	D-IR16-32	4.43	3.95	1.04	1.23	0.88	2-1/8	1-1/2
1-1/4	1-1/2	D-IR20-24	4.10	3.23	1.53	1.62	1.09	1-7/8	2-1/4



## REDUCER

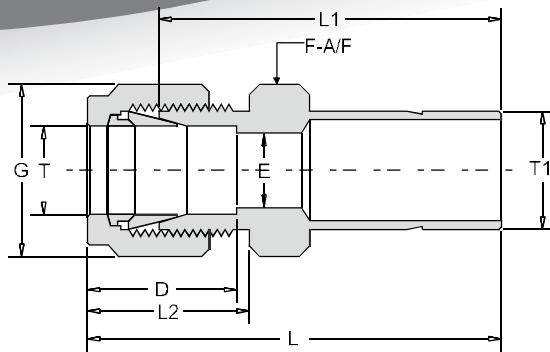

T TUBE O.D.	T1 TUBE O.D.	PART NO.	L	L1	L2	D	E	F HEX FLAT	G HEX FLAT
-------------------	--------------------	----------	---	----	----	---	---	------------------	------------------

### DIMENSION IN MILLIMETERS

6	8	D-MR6-8	39.9	32.5	17.7	15.3	4.8	14	14
6	10	D-MR6-10	40.7	33.3	17.7	15.3	4.8	14	14
6	12	D-MR6-12	46.3	38.9	17.7	15.3	4.8	14	14
8	6	D-MR8-6	40.3	32.8	18.6	16.2	4.6	15	16
8	10	D-MR8-10	42.0	34.5	18.6	16.2	6.4	15	16
10	6	D-MR10-6	42.4	34.8	19.5	17.2	4.6	18	19
10	8	D-MR10-8	43.4	35.8	19.5	17.2	6.4	18	19
10	12	D-MR10-12	49.8	42.2	19.5	17.2	7.9	18	19
12	6	D-MR12-6	44.9	34.8	22.0	22.8	4.6	22	22
12	8	D-MR12-8	45.9	35.8	22.0	22.8	6.4	22	22
12	10	D-MR12-10	46.7	36.6	22.0	22.8	7.7	22	22
12	16	D-MR12-16	53.8	43.7	22.0	22.8	9.5	22	22
12	18	D-MR12-18	53.8	43.7	22.0	22.8	9.5	22	22
16	12	D-MR16-12	53.0	42.9	22.0	24.4	9.1	24	25
18	12	D-MR18-12	54.6	44.5	22.0	24.4	9.1	27	30
18	16	D-MR18-16	56.1	46.0	22.0	24.4	12.7	27	30
18	20	D-MR18-20	57.6	47.5	22.0	24.4	15.1	27	30
18	25	D-MR18-25	62.4	52.3	22.0	24.4	15.1	27	30
20	16	D-MR20-16	57.9	47.8	22.0	26.0	12.7	30	32
20	18	D-MR20-18	57.9	47.8	22.0	26.0	13.9	30	32
20	25	D-MR20-25	64.2	54.1	22.0	26.0	15.8	30	32
22	18	D-MR22-18	57.9	47.8	22.0	26.0	13.9	30	32
22	20	D-MR22-20	59.4	49.3	22.0	26.0	15.8	30	32
22	25	D-MR25-25	64.2	54.1	22.0	26.0	18.3	30	32
25	18	D-MR25-18	63.1	50.8	26.5	31.3	13.9	35	38
25	20	D-MR25-20	64.6	52.3	26.5	31.3	15.1	35	38

## PORT CONNECTOR

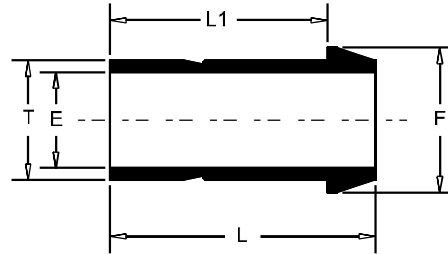

T TUBE O.D.	PART NO.	L	L1	E	F
-------------------	----------	---	----	---	---

### DIMENSION IN INCHES

1/8	D-IPC2	0.88	0.62	0.09	0.24
1/4	D-IPC4	0.97	0.74	0.19	0.37
3/8	D-IPC6	1.03	0.80	0.30	0.50
1/2	D-IPC8	1.41	1.02	0.39	0.62
3/4	D-IPC12	1.47	1.09	0.59	0.87
	D-IPC16	1.89	1.36	0.80	1.12



T TUBE O.D.	PART NO.	L	L1	E	F
-------------------	----------	---	----	---	---

### DIMENSION IN MILLIMETERS

6	D-MPC6	24.6	18.7	4.4	9.0
8	D-MPC8	25.9	20.0	6.2	11.0
10	D-MPC10	26.1	20.2	8.2	13.1
12	D-MPC12	35.8	26.0	9.1	15.0
15	D-MPC15	37.4	27.6	12.7	19.0
16	D-MPC16	37.4	27.6	12.7	19.0
18	D-MPC18	37.4	27.6	13.9	21.0
20	D-MPC20	38.9	29.2	15.1	23.0
25	D-MPC25	48.0	34.5	19.8	28.0
28	D-MPC28	63.5	48.3	23.8	46.0
32	D-MPC32	69.7	52.4	27.4	39.5

## REDUCING PORT CONNECTOR

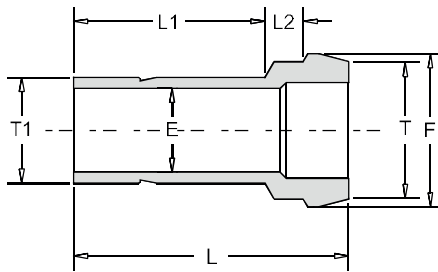

T TUBE O.D.	T1 REDUCED TUBE O.D.	PART NO.	L	L1	L2	E	F
-------------------	-------------------------------	----------	---	----	----	---	---

DIMENSION IN INCHES

1/4	1/8	D-IRPC4-2	0.89	0.53	0.1	0.09	0.37
3/8	1/8	D-IRPC6-2	0.91	0.53	0.15	0.09	0.50
1/2	1/4	D-IRPC6-8	0.98	0.62	0.13	0.19	0.50
1/2	1/4	D-IRPC8-4	1.15	0.62	0.15	0.19	0.62
1/2	3/8	D-IRPC8-6	1.20	0.69	0.13	0.28	0.62
3/4	1/2	D-IRPC12-8	1.44	0.91	0.15	0.39	0.87

T TUBE O.D.	T1 REDUCED TUBE O.D.	PART NO.	L	L1	L2	E	F
-------------------	-------------------------------	----------	---	----	----	---	---

DIMENSION IN MILLIMETERS

8	6	D-MRPC8-6	24.7	15.7	3.1	4.6	11.0
10	6	D-MRPC10-6	25.0	15.7	3.4	4.6	13.1
10	8	D-MRPC10-8	26.0	17.0	3.1	6.4	13.1
12	6	D-MRPC12-6	29.1	15.7	3.6	4.6	15.0
12	8	D-MRPC12-8	29.8	16.8	3.4	6.4	15.0
12	10	D-MRPC12-10	30.4	17.5	3.1	7.7	15.0
16	12	D-MRPC16-12	36.2	23.1	3.4	9.1	19.0
28	25	D-MRPC28-25	56.5	33.0	8.2	19.8	34.3
32	25	D-MRPC32-25	60.3	33.0	9.9	19.8	39.5

## CAP

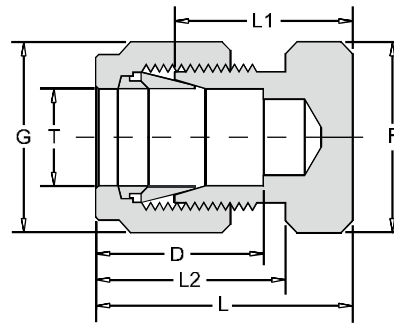

T TUBE O.D.	PART NO.	L	L1	L2	D	F HEX FLAT	G HEX FLAT
-------------------	----------	---	----	----	---	------------------	------------------

### DIMENSION IN INCHES

1/8	D-IC4	0.79	0.53	0.60	0.50	7/16	7/16
3/16	D-IC5	0.84	0.58	0.63	0.54	7/16	1/2
1/4	D-IC4	0.92	0.63	0.70	0.60	1/2	9/16
5/16	D-IC5	0.96	0.67	0.73	0.64	9/16	5/8
3/8	D-IC6	1.01	0.72	0.76	0.66	5/8	11/16
1/2	D-IC8	1.15	0.75	0.86	0.90	13/16	7/8
5/8	D-IC10	1.18	0.78	0.86	0.96	15/16	1
3/4	D-IC12	1.24	0.84	0.86	0.96	1-1/16	1-1/8
7/8	D-IC12	1.34	0.94	0.86	1.02	1-3/16	1-1/4
1	D-IC16	1.51	1.03	1.04	1.23	1-3/8	1-1/2
1-1/4	D-IC16	2.10	1.23	1.53	1.62	1-3/4	1-7/8

T TUBE O.D.	PART NO.	L	L1	L2	D	F HEX FLAT	G HEX FLAT
-------------------	----------	---	----	----	---	------------------	------------------

### DIMENSION IN MILLIMETERS

8	D-MC8	24.5	17.0	18.6	16.2	15	16
10	D-MC10	26.6	19.0	19.5	17.2	18	19
12	D-MC12	29.1	19.0	22.0	17.2	22	22
14	D-MC14	29.9	19.8	22.0	22.8	24	25
15	D-MC15	29.9	19.8	22.0	24.4	24	25
16	D-MC16	29.9	19.8	22.0	24.4	24	25
18	D-MC18	31.4	21.3	22.0	24.4	27	30
20	D-MC20	34.0	23.9	22.0	26.0	30	32
22	D-MC22	34.0	23.9	22.0	26.0	30	32
25	D-MC25	38.5	26.5	26.5	31.3	35	38

## MALE ADAPTER

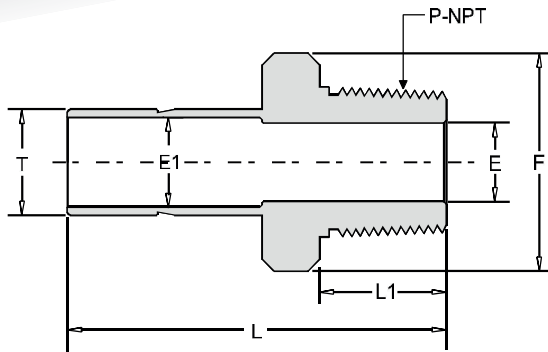

T TUBE OD O.D.	P-NPT MALE THREAD	PART NO.	L	L1	E	E1	F
----------------------	-------------------------	----------	---	----	---	----	---

### DIMENSION IN INCHES

1/8	1/8	D-IMA2-2	1.16	0.38	0.19	0.09	7/16
1/8	1/4	D-IMA2-4	1.38	0.56	0.28	0.09	9/16
1/4	1/8	D-IMA4-2	1.25	0.38	0.19	0.19	7/16
1/4	1/4	D-IMA4-4	1.56	0.56	0.19	0.19	9/16
1/4	3/8	D-IMA4-6	1.49	0.56	0.19	0.19	11/16
1/4	1/2	D-IMA4-8	1.71	0.75	0.19	0.19	7/8
5/16	1/8	D-IMA5-2	1.29	0.38	0.19	0.25	7/16
5/16	1/4	D-IMA5-4	1.50	0.56	0.25	0.25	9/16
3/8	1/8	D-IMA6-2	1.32	0.38	0.19	0.28	7/16
3/8	1/4	D-IMA6-4	1.53	0.56	0.28	0.28	9/16
3/8	3/8	D-IMA6-6	1.56	0.56	0.28	0.28	11/16
3/8	1/2	D-IMA6-8	1.78	0.75	0.28	0.28	7/8
1/2	1/4	D-IMA8-4	1.75	0.56	0.28	0.39	9/16
1/2	3/8	D-IMA8-6	1.78	0.56	0.39	0.39	11/16
1/2	1/2	D-IMA8-8	2.00	0.75	0.39	0.39	7/8
5/8	1/2	D-IMA10-8	2.06	0.75	0.47	0.50	7/8
3/4	1/2	D-IMA12-8	2.06	0.75	0.47	0.59	7/8
3/4	3/4	D-IMA12-12	2.06	0.75	0.59	0.59	1-11/16
1	3/4	D-IMA16-12	2.31	0.75	0.62	0.80	1-1/16
1	1	D-IMA16-16	2.60	0.94	0.80	0.80	1-3/8

## MALE ADAPTER

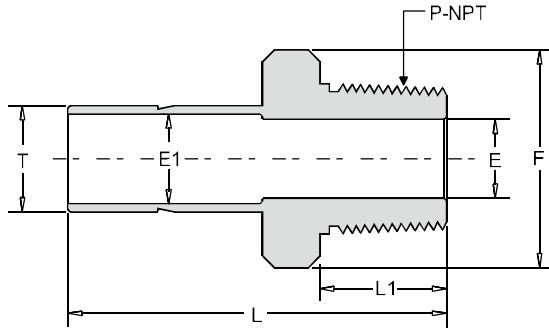

T TUBE O.D.	P-NPT MALE THREAD	PART NO.	L	L1	E	E1	F
-------------------	-------------------------	----------	---	----	---	----	---

**DIMENSION IN MILLIMETERS**

6	1/8	D-MMA6-2	32.8	9.7	4.6	4.6	11.2
6	1	D-MMA6-4	38.1	14.2	4.6	4.6	14.2
8	1/4	D-MMA8-4	39.1	14.2	6.4	4.6	14.2
10	1/4	D-MMA10-4	39.9	14.2	7.1	7.7	14.2
10	3/8	D-MMA10-6	40.6	14.2	7.1	7.7	17.5
10	1/2	D-MMA10-8	46.2	19.1	7.7	7.7	22.4
12	1/4	D-MMA12-4	46.2	14.2	7.7	9.1	15.7
12	1/2	D-MMA12-8	42.0	19.1	9.1	9.1	22.4

## FEMALE ADAPTER

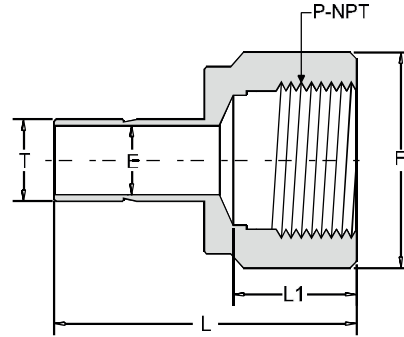

T TUBE OD O.D.	P-NPT FEMALE THREAD	PART NO.	L	L1	E	F
DIMENSION IN INCHES						
1/8	1/8	D-IFA2-2	1.24	0.41	0.09	9/16
1/8	1/4	D-IFA2-4	1.39	0.59	0.09	2/4
1/4	1/8	D-IFA4-2	1.30	0.41	0.19	9/16
1/4	1/4	D-IFA4-4	1.46	0.59	0.19	3/4
1/4	3/8	D-IFA4-6	1.55	0.59	0.19	7/8
1/4	1/2	D-IFA4-8	1.79	0.78	0.19	1-1/16
5/16	1/4	D-IFA5-4	1.48	0.59	0.25	3/4
3/8	1/8	D-IFA6-2	1.35	0.41	0.28	9/16
3/8	1/4	D-IFA6-4	1.50	0.59	0.28	3/4
3/8	3/8	D-IFA6-6	1.59	0.59	0.28	7/8
3/8	1/2	D-IFA6-8	1.84	0.78	0.28	1-1/16
1/2	1/4	D-IFA8-4	1.71	0.59	0.39	3/4
1/2	3/8	D-IFA8-6	1.79	0.59	0.39	7/8
1/2	1/2	D-IFA8-8	2.04	0.78	0.39	1-1/16
5/8	1/2	D-IFA10-8	2.09	0.78	0.50	1-1/16
3/4	1/2	D-IFA12-8	2.08	0.78	0.59	1-1/16
3/4	3/4	D-IFA12-12	2.16	0.81	0.59	1-5/16
3/4	1	D-IFA12-16	2.30	1.00	0.59	1-5/8
1	3/4	D-IFA16-12	2.39	0.81	0.80	1-5/16
1	1	D-IFA16-16	2.53	1.00	0.80	1-5/8



## FEMALE ADAPTER

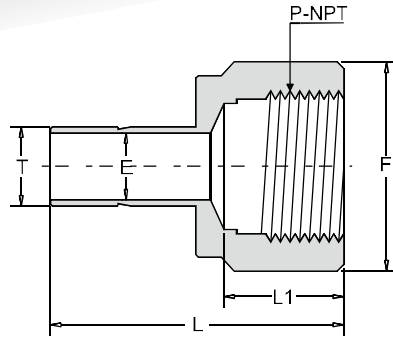

T TUBE O.D.	P-NPT FEMALE THREAD	PART NO.	L	L1	E	F
-------------------	---------------------------	----------	---	----	---	---

### DIMENSION IN MILLIMETERS

6	1/8	D-MFA6-2	29.4	15.9	4.6	14
6	1/4	D-MFA6-4	34.1	15.9	4.6	19
8	1/4	D-MFA8-4	35.1	16.7	6.4	19
10	1/4	D-MFA10-4	37.3	17.5	7.7	19
10	3/8	D-MFA10-6	37.3	17.5	7.7	22
10	1/2	D-MFA10-8	42.1	17.5	7.7	27
12	1/4	D-MFA12-4	41.3	23.0	9.1	19
12	3/8	D-MFA12-6	42.9	23.0	9.1	22
12	1/2	D-MFA12-8	47.6	23.0	9.1	27
16	1/2	D-MFA16-8	49.2	24.6	12.7	27
18	3/4	D-MFA18-12	52.4	24.6	13.9	35
20	1/2	D-MFA20-8	50.0	25.6	15.0	27
20	3/4	D-MFA20-12	53.2	25.4	15.1	35
25	1	D-MFA25-16	66.7	31.8	19.8	41

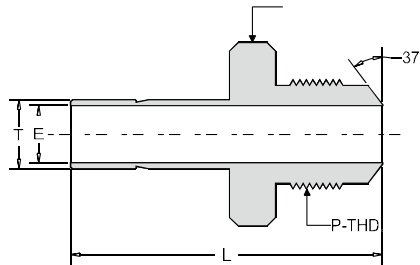

## AN ADAPTER



T TUBE O.D.	AN TUBE FLARE WELD SIZE	PART NO.	L	P THREAD SIZE	E	F
-------------------	-------------------------------------	----------	---	---------------------	---	---

### DIMENSION IN INCHES

1/4	1/4	D-IANA4-4	1.46	7/16-20UNF	0.19	1/2
3/8	1/4	D-IANA6-4	1.53	7/16-20UNF	0.28	1/2
3/8	3/8	D-IANA6-6	1.56	9/16-18UNF	0.28	5/8
1/2	1/2	D-IANA8-8	1.91	3/4-16UNF	0.39	13/16
3/4	3/4	D-IANA12-12	22.1	1-1/16-12UNF	0.59	1-1/8
1	1	D-IANA16-16	2.58	1-5/16-12UNF	0.80	1-3/8

## WELD ADAPTER

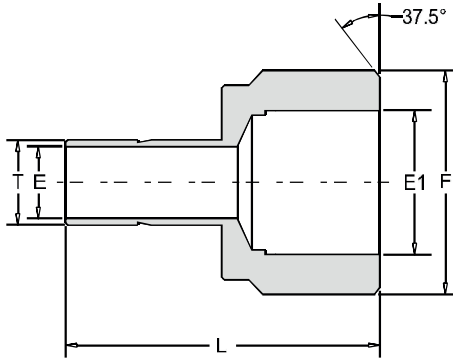

T TUBE O.D.	MALE PIPE WELD SIZE	PART NO.	L	E	E1	F
DIMENSION IN INCHES						
1/4	1/4	D-IWD4-4	1.14	0.19	0.30	0.54
3/8	1/2	D-IWD6-8	1.46	0.28	0.55	0.84
1/2	1/2	D-IWD8-8	1.66	0.39	0.55	0.84
1/2	3/4	D-IWD8-12	1.68	0.39	0.73	1.05
3/4	3/8	D-IWD12-6	1.87	0.59	0.73	1.05

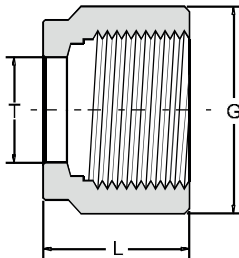

## NUT

T TUBE O.D.	PART NO.	G	L	T TUBE O.D.	PART NO.	L	E
DIMENSION IN INCHES				DIMENSION IN INCHES			
1/16	D-INN1	5/16	0.31	4	D-MNN4	12	11.9
1/8	D-INN2	7/16	0.47	6	D-MNN6	14	12.7
3/16	D-INN3	1/2	0.47	8	D-MNN8	16	13.5
1/4	D-INN4	9/16	0.50	10	D-MNN10	19	15.1
5/16	D-INN5	5/8	0.53	12	D-MNN12	22	17.4
3/8	D-INN6	11/16	0.56	14	D-MNN14	25	17.4
1/2	D-INN8	7/8	0.69	15	D-MNN15	25	17.4
5/8	D-INN10	1	0.69	16	D-MNN16	25	17.4
3/4	D-INN12	1-1/8	0.69	18	D-MNN18	30	17.4
1	D-INN16	1-1/2	0.81	20	D-MNN20	32	17.4
1-1/4	D-INN20	1-7/8	1.25	22	D-MNN22	32	17.4
				25	D-MNN25	38	20.6

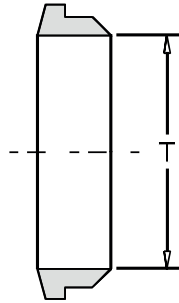

**BACK FERRULE**

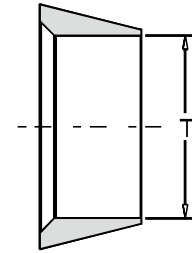

**FRONT FERRULE**

## BACK FERRULE

T TUBE O.D.	PART NO.
DIMENSION IN INCHES	
1/16	D-IBF1
1/8	D-IBF2
3/16	D-IBF3
1/4	D-IBF4
5/16	D-IBF5
3/8	D-IBF6
1/2	D-IBF8
5/8	D-IBF10
3/4	D-IBF12
7/8	D-IBF14
1	D-IBF16
1-1/4	D-IBF20

T TUBE O.D.	PART NO.
DIMENSION IN MILLIMETERS	
4	D-MBF4
6	D-MBF6
8	D-MBF8
10	D-MBF10
12	D-MBF12
14	D-MBF14
15	D-MBF15
16	D-MBF16
18	D-MBF18
20	D-MBF20
22	D-MBF22
25	D-MBF25

## FRONT FERRULE

T TUBE O.D.	PART NO.
DIMENSION IN INCHES	
1/16	D-IBF1
1/8	D-IBF2
3/16	D-IBF3
1/4	D-IBF4
5/16	D-IBF5
3/8	D-IBF6
1/2	D-IBF8
5/8	D-IBF10
3/4	D-IBF12
7/8	D-IBF14
1	D-IBF16
1-1/4	D-IBF20

T TUBE O.D.	PART NO.
DIMENSION IN MILLIMETERS	
4	D-MBF4
6	D-MBF6
8	D-MBF8
10	D-MBF10
12	D-MBF12
14	D-MBF14
15	D-MBF15
16	D-MBF16
18	D-MBF18
20	D-MBF20
22	D-MBF22
25	D-MBF25

## Tubing en Acero Inoxidable Tipo 316/316L

Tubing Sin Costura

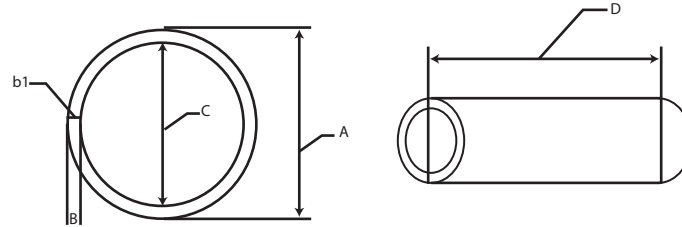

Part No.	A	B	b1	C	D
	Diámetro Exterior	Pared	Calibre	Diámetro Interior	Longitud
DST-2-18-49-SS	1/8	0.049"	18	0.027	6.10 Mts (20 Pies)
DST-2-20-35-SS	1/8	0.035"	20	0.055	6.10 Mts (20 Pies)
DST-3-20-35-SS	3/16	0.035"	20	0.117	6.10 Mts (20 Pies)
DST-4-16-65-SS	1/4	0.065"	16	0.12	6.10 Mts (20 Pies)
DST-4-18-49-SS	1/4	0.049"	18	0.152	6.10 Mts (20 Pies)
DST-4-20-35-SS	1/4	0.035"	20	0.18	6.10 Mts (20 Pies)
DST-5-16-65-SS	5/16	0.065"	16	0.183	6.10 Mts (20 Pies)
DST-5-18-49-SS	5/16	0.049"	18	0.215	6.10 Mts (20 Pies)
DST-5-20-35-SS	5/16	0.035"	20	0.243	6.10 Mts (20 Pies)
DST-6-16-65-SS	3/8	0.065"	16	0.245	6.10 Mts (20 Pies)
DST-6-18-49-SS	3/8	0.049"	18	0.277	6.10 Mts (20 Pies)
DST-6-20-35-SS	3/8	0.035"	20	0.305	6.10 Mts (20 Pies)
DST-8-14-83-SS	1/2	0.083"	14	0.334	6.10 Mts (20 Pies)
DST-8-16-65-SS	1/2	0.065"	16	0.37	6.10 Mts (20 Pies)
DST-8-18-49-SS	1/2	0.049"	18	0.402	6.10 Mts (20 Pies)
DST-8-20-35-SS	1/2	0.035"	20	0.43	6.10 Mts (20 Pies)
DST-10-14-83-SS	5/8	0.083"	14	0.459	6.10 Mts (20 Pies)
DST-10-16-65-SS	5/8	0.065"	16	0.495	6.10 Mts (20 Pies)
DST-10-18-49-SS	5/8	0.049"	18	0.527	6.10 Mts (20 Pies)
DST-10-20-35-SS	5/8	0.035"	20	0.555	6.10 Mts (20 Pies)
DST-12-13-95-SS	3/4	0.095"	13	0.560	6.10 Mts (20 Pies)
DST-12-14-83-SS	3/4	0.083"	14	0.584	6.10 Mts (20 Pies)
DST-12-16-65-SS	3/4	0.065"	16	0.620	6.10 Mts (20 Pies)
DST-12-18-49-SS	3/4	0.049"	18	0.652	6.10 Mts (20 Pies)
DST-12-20-35-SS	3/4	0.035"	20	0.680	6.10 Mts (20 Pies)
DST-16-12-109-SS	1"	0.109"	12	0.782	6.10 Mts (20 Pies)
DST-16-13-95-SS	1"	0.095"	13	0.810	6.10 Mts (20 Pies)
DST-16-14-83-SS	1"	0.083"	14	0.834	6.10 Mts (20 Pies)
DST-16-16-65-SS	1"	0.065"	16	0.870	6.10 Mts (20 Pies)
DST-16-18-49-SS	1"	0.049"	18	0.902	6.10 Mts (20 Pies)
DST-16-20-35-SS	1"	0.035"	20	0.930	6.10 Mts (20 Pies)-